

# How delta-sigma ADCs work, Part 1

By **Bonnie Baker**

*Signal Integrity Engineer*

Analog techniques have dominated signal processing for years, but digital techniques are slowly encroaching into this domain. The design of delta-sigma ( $\Delta\Sigma$ ) analog-to-digital converters (ADCs) is approximately three-quarters digital and one-quarter analog.  $\Delta\Sigma$  ADCs are now ideal for converting analog signals over a wide range of frequencies, from DC to several megahertz. Basically, these converters consist of an oversampling modulator followed by a digital/decimation filter that together produce a high-resolution data-stream output. This two-part article will look closely at the  $\Delta\Sigma$  ADC's core. Part 1 will explore the basic topology and function of the  $\Delta\Sigma$  modulator, and Part 2 will explore the basic topology and function of the digital/decimation filter module.

## $\Delta\Sigma$ converters: An overview

The rudimentary  $\Delta\Sigma$  converter is a 1-bit sampling system. An analog signal applied to the input of the converter needs to be relatively slow so the converter can sample it multiple times, a technique known as oversampling. The sampling rate is hundreds of times faster than the digital results at the output ports. Each individual sample is accumulated over time and “averaged” with the other input-signal samples through the digital/decimation filter.

The  $\Delta\Sigma$  converter's primary internal cells are the  $\Delta\Sigma$  modulator and the digital/decimation filter. The internal  $\Delta\Sigma$  modulator shown in Figure 1 coarsely samples the input signal at a very high rate into a 1-bit stream. The digital/decimation filter then takes this sampled data and converts it into a high-resolution, slower digital code. While most converters have one sample rate, the  $\Delta\Sigma$  converter has two—the input sampling rate ( $f_S$ ) and the output data rate ( $f_D$ ).

## The $\Delta\Sigma$ modulator

The  $\Delta\Sigma$  modulator is the heart of the  $\Delta\Sigma$  ADC. It is responsible for digitizing the analog input signal and reducing noise at lower frequencies. In this stage, the architecture implements a function called noise shaping that pushes low-frequency noise up to higher frequencies where it is outside the band of interest. Noise shaping is one of the reasons that  $\Delta\Sigma$  converters are well-suited for low-frequency, high-accuracy measurements.

The input signal to the  $\Delta\Sigma$  modulator is a time-varying analog voltage. With the earlier  $\Delta\Sigma$  ADCs, this input-voltage signal was primarily for audio applications where AC signals were important. Now that attention has turned to precision applications, conversion rates include DC signals. This discussion will use a single cycle of a sine wave for illustration.

**Figure 1. Block diagram of  $\Delta\Sigma$  ADC**

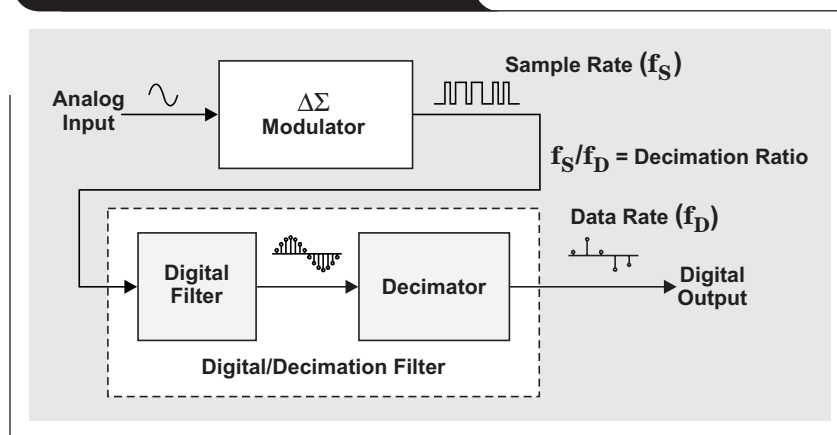

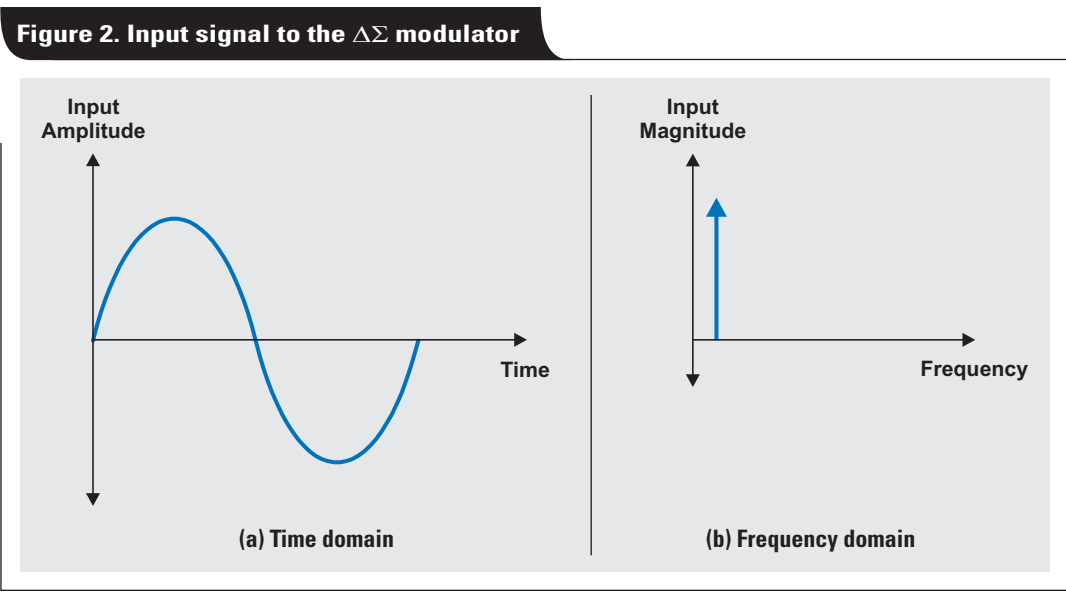

Figure 2a shows a single cycle of a sine wave for the input of a  $\Delta\Sigma$  modulator. This single cycle has voltage amplitude that changes with time. Figure 2b shows a frequency-domain representation of the time-domain signal in Figure 2a. The curve in Figure 2b represents the continuous sine wave in Figure 2a and appears as a straight line or a spur.

There are two ways to look at the  $\Delta\Sigma$  modulator—in the time domain (Figure 3) or in the frequency domain (Figure 4). The time-domain block diagram in Figure 3 shows the mechanics of a first-order  $\Delta\Sigma$  modulator. The modulator converts the analog input signal to a high-speed, single-bit, modulated pulse wave. More importantly, the frequency analysis in Figure 4 shows how the modulator affects the noise in the system and facilitates the production of a higher-resolution result.

The  $\Delta\Sigma$  modulator shown in Figure 3 acquires many samples of the input signal to produce a stream of 1-bit codes. The system clock implements the sampling speed,  $f_s$ , in conjunction with the modulator's 1-bit comparator.

In this manner, the quantizing action of the  $\Delta\Sigma$  modulator is produced at a high sample rate that is equal to that of the system clock. Like all quantizers, the  $\Delta\Sigma$  modulator produces a stream of digital values that represent the voltage of the input, in this case a 1-bit stream. As a result, the ratio of the number of ones to zeros represents the input analog voltage. Unlike most quantizers, the  $\Delta\Sigma$  modulator includes an integrator, which has the effect of shaping the quantization noise to higher frequencies. Consequently, the noise spectrum at the output of the modulator is not flat.

In the time domain, the analog input voltage and the output of the 1-bit digital-to-analog converter (DAC) are differentiated, providing an analog voltage at  $x_2$ . This voltage is presented to the integrator, whose output progresses in a negative or positive direction. The slope and direction of the signal at  $x_3$  is dependent on the sign and magnitude of the voltage at  $x_2$ . At the time the voltage at  $x_3$  equals the comparator reference voltage, the output of the comparator switches from negative to positive, or positive to negative,

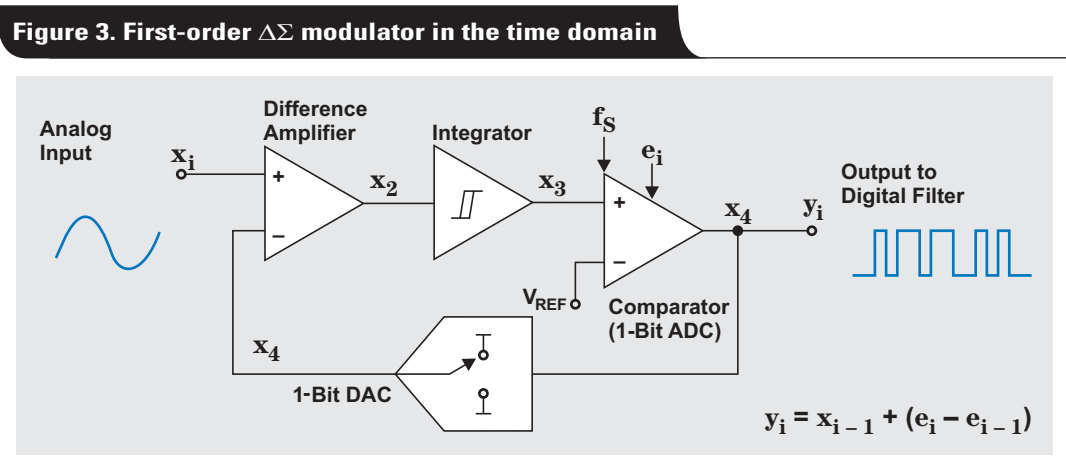

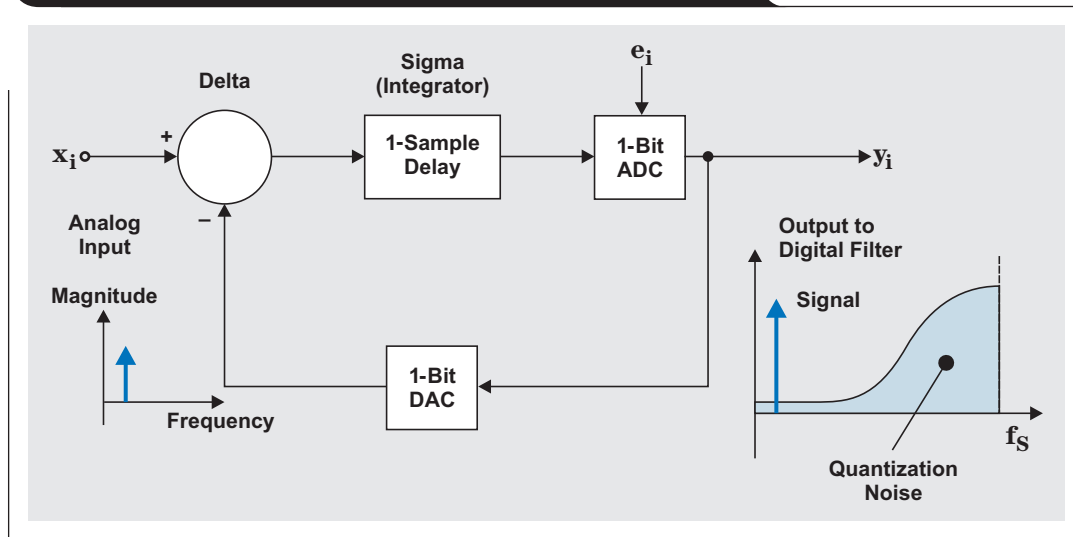
**Figure 4. First-order  $\Delta\Sigma$  modulator in the frequency domain**

depending on its original state. The output value of the comparator,  $x_4$ , is clocked back into the 1-bit DAC, as well as clocked out to the digital filter stage,  $y_i$ . At the time that the output of the comparator switches from high to low or vice versa, the 1-bit DAC responds by changing the analog output voltage of the difference amplifier. This creates a different output voltage at  $x_2$ , causing the integrator to progress in the opposite direction. This time-domain output signal is a pulse-wave representation of the input signal at the sampling rate ( $f_s$ ). If the output pulse train is averaged, it equals the value of the input signal.

The discrete-time block diagram in Figure 3 also shows the time-domain transfer function. In the time domain, the 1-bit ADC digitizes the signal to a coarse, 1-bit output code that produces the quantization noise of the converter. The output of the modulator is equal to the input plus the quantization noise,  $e_i - e_{i-1}$ . As this formula shows, the quantization noise is the difference between the current quantization error ( $e_i$ ) and the previous quantization error ( $e_{i-1}$ ). Figure 4 illustrates the frequency location of this quantization noise.

Figure 4 also shows that the combination of the integrator and sampling strategy implements a noise-shaping filter on the digital output code. In the frequency domain, the time-domain output pulses appear as the input signal (or spur) and shaped noise. The noise characteristics in Figure 4 are the key to understanding the modulator's frequency operation and the ability of the  $\Delta\Sigma$  ADC to achieve such high resolution.

The noise in the modulator is moved out to higher frequencies. Figure 4 shows that the quantization noise for a first-order modulator starts low at zero hertz, rises rapidly, and then levels off at a maximum value at the modulator's sampling frequency ( $f_s$ ).

Using a circuit that integrates twice instead of just once is a great way to lower the modulator's in-band quantization noise. Figure 5 shows a 1-bit, second-order modulator that has two integrators instead of one. With this second-order modulator example, the noise term depends on not just the previous error but the previous two errors.

Some of the disadvantages of the second- or multi-order modulators include increased complexity, multiple loops,

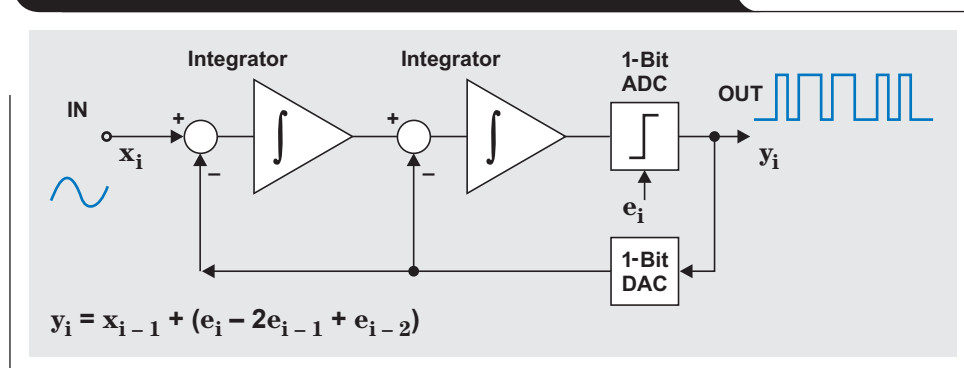
**Figure 5. Block diagram of a second-order  $\Delta\Sigma$  modulator**

and increased design difficulty. However, most  $\Delta\Sigma$  modulators are higher-order, like the one in Figure 5. For instance, Texas Instruments  $\Delta\Sigma$  converters include second- through sixth-order modulators.

Multi-order modulators shape the quantization noise to even higher frequencies than do the lower-order modulators. In Figure 6, the highest line at the frequency  $f_s$  shows the third-order modulator's noise response. Note that this modulator's output is very noisy all the way out at its sampling frequency of  $f_s$ . However, down at lower frequencies, below  $f_D$  and near the input-signal spur, the third-order modulator is very quiet.  $f_D$  is the conversion frequency of the digital/decimation filter. Selecting a value for  $f_D$  will be discussed in Part 2 of this article series.

### Modulators: The first half of the story

The modulator of the  $\Delta\Sigma$  ADC successfully reduces low-frequency noise during the conversion process. However, the high-frequency noise is a problem and is undesirable

in the final output of the converter. Part 2 of this article series will discuss how to get rid of this noise with a low-pass digital/decimation filter.

### References

1. R. Jacob Baker, *CMOS: Mixed-Signal Circuit Design*, Vol. II. John Wiley & Sons, 2002.
2. Texas Instruments, *Nuts and Bolts of the Delta-Sigma Video Tutorial* [Online]. Available: <http://focus.ti.com/docs/training/catalog/events/event.jhtml?sku=WEB408001>

### Related Web site

[dataconverter.ti.com](http://dataconverter.ti.com)

**Figure 6.  $\Delta\Sigma$  modulator noise shaping versus modulator order with a sampling frequency of  $f_s$**

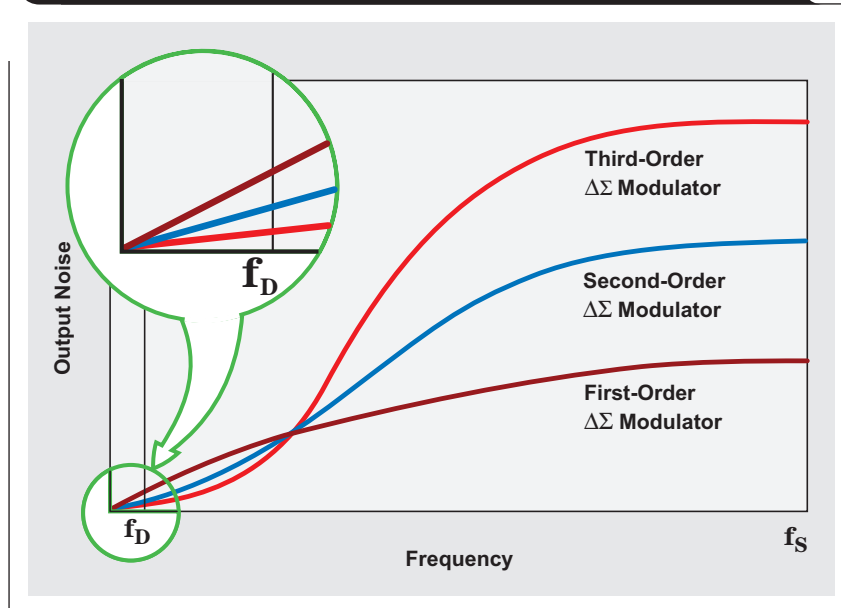

# TI Worldwide Technical Support

---

## Internet

### TI Semiconductor Product Information Center Home Page

[support.ti.com](http://support.ti.com)

### TI E2E™ Community Home Page

[e2e.ti.com](http://e2e.ti.com)

## Product Information Centers

<b>Americas</b>	Phone	+1(972) 644-5580
<b>Brazil</b>	Phone	0800-891-2616
<b>Mexico</b>	Phone	0800-670-7544
	Fax	+1(972) 927-6377
	Internet/Email	<a href="http://support.ti.com/sc/pic/americas.htm">support.ti.com/sc/pic/americas.htm</a>

## Europe, Middle East, and Africa

Phone	
European Free Call	00800-ASK-TEXAS (00800 275 83927)
International	+49 (0) 8161 80 2121
Russian Support	+7 (4) 95 98 10 701

**Note:** The European Free Call (Toll Free) number is not active in all countries. If you have technical difficulty calling the free call number, please use the international number above.

Fax	+ (49) (0) 8161 80 2045
Internet	<a href="http://support.ti.com/sc/pic/euro.htm">support.ti.com/sc/pic/euro.htm</a>
Direct Email	<a href="mailto:asktexas@ti.com">asktexas@ti.com</a>

## Japan

Phone	Domestic	0120-92-3326
Fax	International	+81-3-3344-5317
	Domestic	0120-81-0036
Internet/Email	International	<a href="http://support.ti.com/sc/pic/japan.htm">support.ti.com/sc/pic/japan.htm</a>
	Domestic	<a href="http://www.tij.co.jp/pic">www.tij.co.jp/pic</a>

## Asia

Phone	
International	+91-80-41381665
Domestic	<u>Toll-Free Number</u>
<b>Note:</b> Toll-free numbers do not support mobile and IP phones.	
Australia	1-800-999-084
China	800-820-8682
Hong Kong	800-96-5941
India	1-800-425-7888
Indonesia	001-803-8861-1006
Korea	080-551-2804
Malaysia	1-800-80-3973
New Zealand	0800-446-934
Philippines	1-800-765-7404
Singapore	800-886-1028
Taiwan	0800-006800
Thailand	001-800-886-0010

Fax	+8621-23073686
Email	<a href="mailto:tiasia@ti.com">tiasia@ti.com</a> or <a href="mailto:ti-china@ti.com">ti-china@ti.com</a>
Internet	<a href="http://support.ti.com/sc/pic/asia.htm">support.ti.com/sc/pic/asia.htm</a>

**Important Notice:** The products and services of Texas Instruments Incorporated and its subsidiaries described herein are sold subject to TI's standard terms and conditions of sale. Customers are advised to obtain the most current and complete information about TI products and services before placing orders. TI assumes no liability for applications assistance, customer's applications or product designs, software performance, or infringement of patents. The publication of information regarding any other company's products or services does not constitute TI's approval, warranty or endorsement thereof.

**A122010**

E2E is a trademark of Texas Instruments. All other trademarks are the property of their respective owners.

## IMPORTANT NOTICE

Texas Instruments Incorporated and its subsidiaries (TI) reserve the right to make corrections, modifications, enhancements, improvements, and other changes to its products and services at any time and to discontinue any product or service without notice. Customers should obtain the latest relevant information before placing orders and should verify that such information is current and complete. All products are sold subject to TI's terms and conditions of sale supplied at the time of order acknowledgment.

TI warrants performance of its hardware products to the specifications applicable at the time of sale in accordance with TI's standard warranty. Testing and other quality control techniques are used to the extent TI deems necessary to support this warranty. Except where mandated by government requirements, testing of all parameters of each product is not necessarily performed.

TI assumes no liability for applications assistance or customer product design. Customers are responsible for their products and applications using TI components. To minimize the risks associated with customer products and applications, customers should provide adequate design and operating safeguards.

TI does not warrant or represent that any license, either express or implied, is granted under any TI patent right, copyright, mask work right, or other TI intellectual property right relating to any combination, machine, or process in which TI products or services are used. Information published by TI regarding third-party products or services does not constitute a license from TI to use such products or services or a warranty or endorsement thereof. Use of such information may require a license from a third party under the patents or other intellectual property of the third party, or a license from TI under the patents or other intellectual property of TI.

Reproduction of TI information in TI data books or data sheets is permissible only if reproduction is without alteration and is accompanied by all associated warranties, conditions, limitations, and notices. Reproduction of this information with alteration is an unfair and deceptive business practice. TI is not responsible or liable for such altered documentation. Information of third parties may be subject to additional restrictions.

Resale of TI products or services with statements different from or beyond the parameters stated by TI for that product or service voids all express and any implied warranties for the associated TI product or service and is an unfair and deceptive business practice. TI is not responsible or liable for any such statements.

TI products are not authorized for use in safety-critical applications (such as life support) where a failure of the TI product would reasonably be expected to cause severe personal injury or death, unless officers of the parties have executed an agreement specifically governing such use. Buyers represent that they have all necessary expertise in the safety and regulatory ramifications of their applications, and acknowledge and agree that they are solely responsible for all legal, regulatory and safety-related requirements concerning their products and any use of TI products in such safety-critical applications, notwithstanding any applications-related information or support that may be provided by TI. Further, Buyers must fully indemnify TI and its representatives against any damages arising out of the use of TI products in such safety-critical applications.

TI products are neither designed nor intended for use in military/aerospace applications or environments unless the TI products are specifically designated by TI as military-grade or "enhanced plastic." Only products designated by TI as military-grade meet military specifications. Buyers acknowledge and agree that any such use of TI products which TI has not designated as military-grade is solely at the Buyer's risk, and that they are solely responsible for compliance with all legal and regulatory requirements in connection with such use.

TI products are neither designed nor intended for use in automotive applications or environments unless the specific TI products are designated by TI as compliant with ISO/TS 16949 requirements. Buyers acknowledge and agree that, if they use any non-designated products in automotive applications, TI will not be responsible for any failure to meet such requirements.

Following are URLs where you can obtain information on other Texas Instruments products and application solutions:

### Products

Audio	<a href="http://www.ti.com/audio">www.ti.com/audio</a>
Amplifiers	<a href="http://amplifier.ti.com">amplifier.ti.com</a>
Data Converters	<a href="http://dataconverter.ti.com">dataconverter.ti.com</a>
DLP® Products	<a href="http://www.dlp.com">www.dlp.com</a>
DSP	<a href="http://dsp.ti.com">dsp.ti.com</a>
Clocks and Timers	<a href="http://www.ti.com/clocks">www.ti.com/clocks</a>
Interface	<a href="http://interface.ti.com">interface.ti.com</a>
Logic	<a href="http://logic.ti.com">logic.ti.com</a>
Power Mgmt	<a href="http://power.ti.com">power.ti.com</a>
Microcontrollers	<a href="http://microcontroller.ti.com">microcontroller.ti.com</a>
RFID	<a href="http://www.ti-rfid.com">www.ti-rfid.com</a>
OMAP Mobile Processors	<a href="http://www.ti.com/omap">www.ti.com/omap</a>
Wireless Connectivity	<a href="http://www.ti.com/wirelessconnectivity">www.ti.com/wirelessconnectivity</a>

### Applications

Communications and Telecom	<a href="http://www.ti.com/communications">www.ti.com/communications</a>
Computers and Peripherals	<a href="http://www.ti.com/computers">www.ti.com/computers</a>
Consumer Electronics	<a href="http://www.ti.com/consumer-apps">www.ti.com/consumer-apps</a>
Energy and Lighting	<a href="http://www.ti.com/energy">www.ti.com/energy</a>
Industrial	<a href="http://www.ti.com/industrial">www.ti.com/industrial</a>
Medical	<a href="http://www.ti.com/medical">www.ti.com/medical</a>
Security	<a href="http://www.ti.com/security">www.ti.com/security</a>
Space, Avionics and Defense	<a href="http://www.ti.com/space-avionics-defense">www.ti.com/space-avionics-defense</a>
Transportation and Automotive	<a href="http://www.ti.com/automotive">www.ti.com/automotive</a>
Video and Imaging	<a href="http://www.ti.com/video">www.ti.com/video</a>

TI E2E Community Home Page

[e2e.ti.com](http://e2e.ti.com)

Mailing Address: Texas Instruments, Post Office Box 655303, Dallas, Texas 75265  
Copyright © 2011, Texas Instruments Incorporated