

# A Dual Input Device for Self-Assisted Control of a Virtual Pendulum

Kari A. Danek, R. Brent Gillespie, J. Wayne Aldridge, Daniel P. Ferris, J.W. Grizzle

*Abstract*—We are proposing a new approach to rehabilitation robotics for people who have suffered neurological injuries resulting in impaired motor ability in the lower limbs. The central idea being developed in this research project is to design a teleoperated rehabilitation device that allows an incomplete spinal cord injured (SCI) patient to use their upper limbs, i.e. the intact portion of their neurological system, to direct the mechanical assistance of their lower limbs. This paper presents the design of a single axis dual interface apparatus and its connection to a computationally mediated virtual environment. A preliminary experiment was conducted wherein healthy subjects manipulate a virtual pendulum with their hand, feet, or both to track a pseudo-random signal. Results show that the combined efforts of the hand and feet demonstrate improved tracking performance. We now have an apparatus and associated task for which control sharing between the hand and feet yields benefit for healthy subjects. If further experiments with healthy subjects can demonstrate the benefit of a hand-assisted training phase for ultimate performance with feet alone, then we shall test the hypothesis that this hand-assisted phase can accelerate rehabilitation for neurologically injured patients.

## I. INTRODUCTION

WE propose the development of a new class of rehabilitation robotics for patients with neurological injuries affecting the control of their lower limbs. Recent clinical evidence demonstrates substantial motor recovery can be induced by task-specific training. The key to this important new finding is that the adult nervous system is capable of activity-dependent plasticity [1],[2]. With appropriately timed and organized sensory inputs, neural networks in the brain and spinal cord are capable of change and reorganization. In recent studies, up to 80% of wheelchair-bound incomplete spinal cord injury (SCI) patients undergoing weight-supported treadmill therapy recover some walking skills [3]. The therapy is physically intensive and requires specially trained, highly skilled therapists. Several groups around the world are exploring the possibility of using robots in place of human-delivered therapy [4],[5]. This type of therapy generally uses the robot to drive the patient’s lower limbs through a series of pre-defined trajectories. However, lacking additional motivation, the patient can easily become a passive participant in the motion. One approach to address this problem, called “Patient-cooperative” [6], implements force sensors to gauge the subject’s level of participation. Based on this

Kari Danek (corresponding author) and Brent Gillespie are with the Department of Mechanical Engineering; Wayne Aldridge is with the Department of Psychology and the Department of Neurology; Dan Ferris is with the Department of Biomedical Engineering and the Division of Kinesiology; Jessy Grizzle is with the Department of Electrical Engineering and Computer Science. All authors are at the University of Michigan, Ann Arbor, MI 48109, USA. (e-mail: danekk, brentg, jwaynea, ferrisd, grizzle@umich.edu)

information, the robot’s level of aid or reference trajectory can be adapted to accommodate the patient. We propose an alternative approach: instead of replacing the therapist with an autonomous or even patient accommodating robot, replace the therapist with a patient-controlled robot. We will give direct control over external mechanical assistance of leg movements to the patients’ unaffected limbs (for SCI this would mean their upper extremities). This self-assist approach is in the spirit of the MIME [7] and Driver’s SEAT [8] robotic studies wherein the focus was on bilaterally affected stroke patients. With these, the unaffected arm could assist the affected in completing a task. Patient controlled assistance is hypothesized to improve robot training effectiveness by making the system adaptable to the patient’s intent while making the patient a more active participant in the rehabilitation and utilizing the natural neural coupling within the human body.

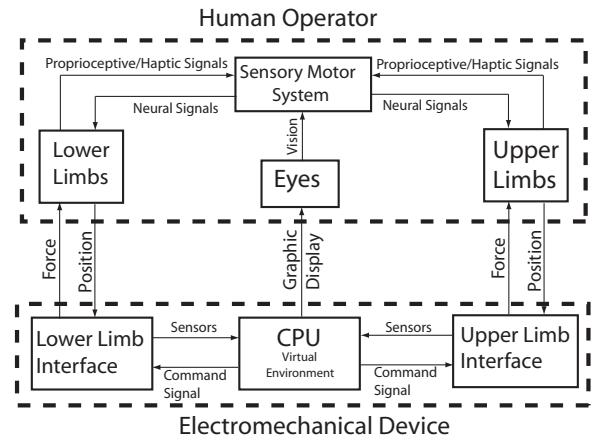

Fig. 1. The upper and lower extremities of the subject are neurally coupled by nature. An additional mechanical coupling between the two limb sets provides another means of information and power transfer.

For patients with an injury that afflicts the lower limbs, assistance can be provided through the use of their upper limbs. Our exploration of the self-assisted rehabilitation idea begins with the development of an electromechanical mechanism with two interfaces: one for the patient’s upper limbs and another for his lower limbs. The block diagram in Figure 1 depicts the various power and information pathways available in our proposed human-machine interface. The neural coupling between a person’s hands and feet through his sensory motor system [9]. The proposed additional mechanical coupling between the upper and lower limbs through an electromechanical device is also illustrated. The operator’s limbs each interface with a robotic system to interact with a single virtual environment.

In its final form, the system will allow for the exchange of tactile (haptic) information between the upper limb and the virtual environment and between the lower limb and the virtual environment. Since both elements interface with the same virtual environment, they can receive information from each other through those environmental interactions. It is the combination of mechanical and neural coupling during the completion of a single task that we hypothesize will promote motor recovery. By appropriate mechanical design (including sensor/actuator selection) and control design, the patient will be able to simultaneously assist and monitor the afflicted limbs. The patient will learn to drive the system with the unaffected effector so as to elicit mechanical forces from the environment and aid the injured limbs to achieve coordinated movement. In effect, the patient will be allowed to direct the retraining of the motion control centers in his brain and spinal cord by using the intact portion of his nervous system. This approach actively engages the patient in the rehabilitation process and prevents him from becoming passive, while promoting the neural association between a certain muscular action and its physical results. Our expected clinical outcome is that the patient trained in a self-directed rehabilitation paradigm will achieve greater functional ability and acquire it at a faster rate than with traditional therapist-directed or computer-directed assistance.

Our long-term goal is to develop an appropriate high degree-of-freedom telemanipulator (featuring a force-reflecting master for the hand and an exoskeleton or powered orthosis for the legs) for rehabilitation of human balance and locomotor function. This paper presents the first of several key ingredients toward achieving this larger goal. Specifically, we have constructed a single-axis, dual-input device to test the hypothesis that patient-directed, self-operated practice of lower limb movement improves lower limb motor control. Currently the device allows input from both the hand and feet. However, haptic feedback is presently only available at the lower limbs. In the first experiment presented here, we use the apparatus to test whether healthy subjects can use their upper limbs to aid their lower limbs in performing a simple motor task. In sections II and III below, we present the design of the apparatus and its use with a computationally mediated virtual environment. Then in section IV we present results from our initial healthy human subject experiment. These results show that by using the combined effort of the hand and feet, subjects can achieve better performance in a simple tracking task.

## II. APPARATUS

The experimental apparatus, shown in Figure 2, consists of two single-axis interfaces to a common virtual environment. One interface is for a hand and the other for the feet. The hand interface is a palm-sized plate that pivots about a horizontal axis under the wrist. It is positioned on a pedestal to the right of the subject at waist height. In its present form, the hand interface is not motorized and thus does not feature haptic feedback. The interface for

the feet is a single-axis platform that pivots about a horizontal axis approximately aligned with the talocrural joint of the ankle. The foot platform is actuated by a low inertia Kollmorgan GoldLine B-406-B motor with a ServoStar amplifier. The platform and motor are coupled through a cable driven capstan with an 8:1 mechanical advantage. This transmission allows the production of torques comparable to normal ankle capabilities (approximately -150 to 150 Nm) without introducing appreciable backlash into the system. While standing on the platform, the subject's upper body is grounded to the wall with support straps around chest and hips. Although these restraints do not provide body weight support, they act to isolate ankle movement to movement of the platform.

Readings of angular displacement of the platform are provided through a resolver embedded in the motor (encoder #1) and through an auxiliary encoder mounted directly to the rotating shaft of the foot platform (encoder #2). A single-axis torque transducer provides for measurement of the load transmitted to the feet. A third encoder on the hand interface provides a reading of the angular displacement of the hand plate. All encoder and analog input signals and the motor command output signal are communicated to or from a Pentium II computer through a Sensoray 626 data acquisition board. This target computer runs code under the QNX real-time operating system. Development of the real-time control software is managed on a separate host computer by MATLAB/Simulink with autocode generation by Opal-RT.

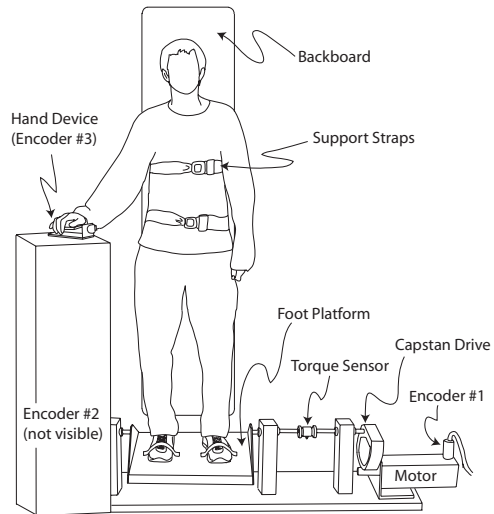

Fig. 2. The test apparatus consists of two interfaces, an actuated foot platform and unactuated hand control device.

## III. VIRTUAL ENVIRONMENT

With this apparatus, interaction between the subject and a computer-generated virtual environment is possible. There are two independent inputs available: the foot and hand angular positions, along with their derivatives. These inputs can be used by a subject individually or in combination to act on a virtual environment. The capability of the motor to apply a torque to the foot platform al-

low the virtual environment to act in turn on the user. Within the virtual environment, images of the hand-plate and foot-platform are made to move with the physical devices. Between the virtual hand-plate and virtual objects, and likewise between the virtual foot-platform and virtual objects, connections can be established through virtual spring-damper pairs, called virtual couplers. The virtual couplers also become the means to compute reaction forces to be fed back from the virtual environment to the subject and rendered through motors. In the present apparatus, reaction torques can be fed back to the feet but not to the hand of the subject.

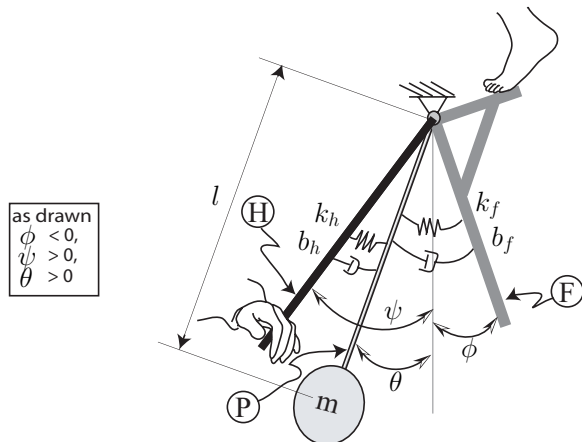

Fig. 3. The virtual pendulum is illustrated as a physical point mass pendulum connected to massless representations of the hand and foot position through spring-damper pairs.

### A. Equations of Motion

A simple yet useful virtual environment to render for initial studies is a stable pendulum. A schematic of the virtual environment and schematic images of the hand-plate and foot-platform are shown in Figure 3. The pendulum  $P$  is modeled as a point mass  $m$  at the end of a massless bar of length  $l$  pivoted to ground through a horizontal axis. Let  $\theta$  describe the angular displacement of the pendulum from the vertical. Also shown in Figure 3 is the massless bar  $F$  whose displacement  $\phi$  from the vertical is driven by the motion of the foot-platform. Likewise, the massless bar  $H$  has an angular displacement  $\psi$  from the vertical that is driven by the hand-plate. The virtual couplings between the virtual pendulum and the images of the hand-plate and foot-platform are shown as spring-damper pairs. Parameters  $k_f$  and  $b_f$  are the stiffness and damping constants of the virtual coupling to the foot-platform and  $k_h$  and  $b_h$  are the hand coupling parameters. The gravitational constant is  $g$  (downward positive). Dynamic equilibrium applied to the system in Figure 3 produces the equations of motion:

$$ml^2\ddot{\theta} + (b_h + b_f)\dot{\theta} + (k_h + k_f)\theta + mgl \sin(\theta) = b_h\dot{\psi} + k_h\psi + b_f\dot{\phi} + k_f\phi \quad (1)$$

The reaction torque that develops due to displacement of the virtual coupler between the image of the foot platform

TABLE I  
POSSIBLE INPUT-OUTPUT CONDITIONS

Condition	$S_1$	$S_2$	$S_3$	Description
1	OFF	OFF	OFF	Null Case
2	OFF	OFF	ON	No Input
3	OFF	ON	OFF	FC, No Fdbk
4	OFF	ON	ON	FC, Fdbk
5	ON	OFF	OFF	HC, No Fdbk
6	ON	OFF	ON	HC, Fdbk
7	ON	ON	OFF	FHC, No Fdbk
8	ON	ON	ON	FHC, Fdbk

Note: Conditions 4, 5, 6, and 8 are tested in this paper.

and the pendulum can be rendered to the subject's foot through the motor. The expression for the torque  $\tau$  to be applied to the foot platform is

$$\tau = -b_f(\dot{\phi} - \dot{\theta}) - k_f(\phi - \theta) \quad (2)$$

### B. Operating Conditions

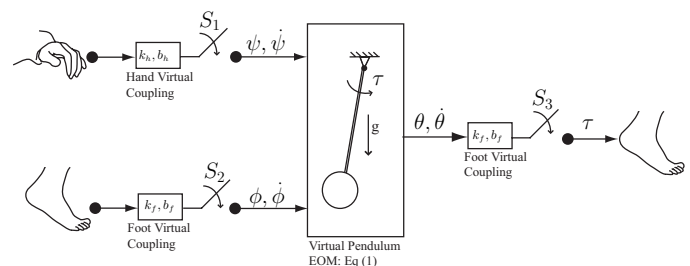

Fig. 4. By changing the state of the three switches ( $S_1, S_2$ , and  $S_3$ ) we can change the input/output configuration of the virtual system.

While the apparatus is capable of using either or both of the two inputs, the hand and foot positions, and producing appropriate reaction torques at the feet, not all inputs to and outputs from the virtual environment need be used in a given experimental scenario. Figure 4 illustrates with schematic switches the various system configurations. By opening or closing the three switches, eight distinct operating configurations are achieved. Table I summarizes the eight configuration options, where FC means foot control, HC means hand control, FHC means both hand and foot control, and Fdbk stands for haptic feedback at the feet.

The first two configurations described in this table have no practical significance for manipulating a virtual pendulum, since without input, the pendulum will simply remain stationary. The other six configurations represent control by the hand only, the foot only, or by both. Note that the various configurations can also be realized directly from eqs. (1) and (2) by adjusting the stiffness and damping coefficients. For instance, by setting  $k_h$  and  $b_h$  equal to zero, we essentially turn off the virtual coupling between the hand and the pendulum, allowing no transfer of power between the two. Since this system is realized virtually, not with physical masses, springs, and dampers, we have great flexibility in adjusting these gains. Instead of a virtual coupling being either ON or OFF, one could imagine

fine tuning those parameters to best meet the performance needs of the task. If we were to make the hand coupling more rigid than the foot coupling, we would be essentially giving the hand input more authority over the virtual pendulum.

#### IV. PRELIMINARY EXPERIMENT

The dual-interface apparatus described above was designed and built for the purpose of studying self assist in the performance of simple motor tasks. Candidate tasks include balancing an inverted pendulum (a stabilization task) or using the pendulum in a pursuit tracking task (a dynamic task). Ultimately we hope to use this device to develop rehabilitation therapies for retraining damaged nerves in partial spinal cord injured patients. However, before attacking these broader goals, we performed a small preliminary experiment involving pursuit tracking by healthy human subjects. This test served two purposes: first, to assess the mechanical capabilities of the apparatus, and second, to determine if the use of hand and foot together can produce superior tracking performance than use of either alone.

##### A. Methods

In this preliminary experiment subjects were asked to manipulate the virtual pendulum to track a pseudo-random signal. Three healthy subjects between the ages of 22 and 24 (one male and two female) participated in the study after providing informed consent. The virtual pendulum had a mass  $m = 35kg$  and a length  $l = 0.9m$ . The virtual coupling parameters were set to  $k_h = k_f = 900Nm/rad$  and  $b_h = b_f = 100Nms/rad$ . In the condition where two effectors control the pendulum, there are two virtual couplers acting on the system. The two springs change the overall stiffness of the dynamic system. The natural frequencies of the free virtual pendulum ( $\omega_p$ ), of the virtual pendulum coupled to one effector ( $\omega_1$ ), and the virtual pendulum coupled to two effectors ( $\omega_2$ ) are

$$\begin{aligned}\omega_p &= \sqrt{g/l} = 3.3rad/s \\ \omega_1 &= \sqrt{(k + mgl)/(ml^2)} = 6.5rad/s \\ \omega_2 &= \sqrt{(2k + mgl)/(ml^2)} = 8.6rad/s.\end{aligned}$$

The target signal to be tracked was generated using a sum of seven sine waves of unevenly distributed (without harmonic inter-relationships) frequencies and unevenly distributed phase shifts. The maximum frequency was set to less than half the natural frequency of the virtual pendulum to enable relatively simple tracking of the target signal, despite the presence of the resonant frequency in the pendulum. The tracking task was performed with four different configurations of control and feedback. These configurations correspond to conditions 4, 5, 6, and 8 from Table I. The four conditions are controlled through the feet alone with force feedback, combined control through the feet and hand with force feedback at the feet, control through the hand alone without force feedback to the feet, and control by the hand with force feedback to the feet. In addition to

proprioceptive feedback of the hand and feet positions, all modes included visual feedback of the pendulum position and the target signal provided through an oscilloscope-type display on a computer monitor. The oscilloscope display provided no preview, but did show the signal history.

Each subject was given two minutes of unrecorded practice time per condition. After the practice period, individual trials testing only one condition at a time were run for three minutes. Three replicates were recorded for a total of twelve three-minute trials per subject. For each subject the twelve tests were administered in a random order to reduce the appearance of training effects in the data. Subjects were instructed that they could pause or terminate the test at any time if they felt discomfort or fatigue. Two subjects performed all trials with only minor breaks between tests for condition changes. One subject took two several minute breaks, both between trials. This disruption did not affect any one particular trial and is not expected to impact the overall test results.

Figure 5 shows a portion of the raw data tracking results for one typical subject. Both the reference signal to be tracked and the subject-controlled virtual pendulum position are shown. At first glance, there is a visually apparent distinction between the tracking performance of these two trials that suggest the control strategy and performance may vary by condition.

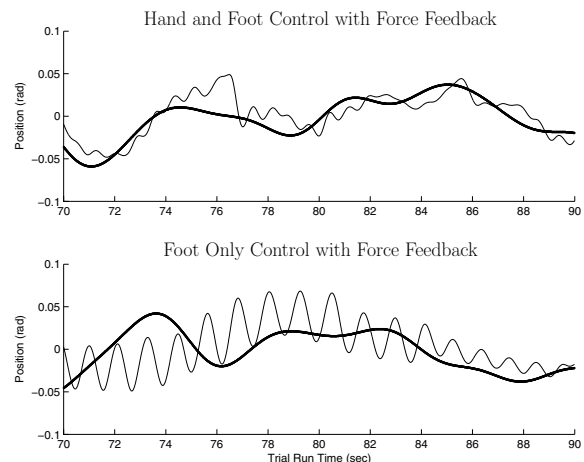

Fig. 5. The subjects were asked to track a pseudo-random signal by manipulating the position of a virtual pendulum coupled to the indicated control interface through a virtual spring-mass pair. The two plots come from a middle 20 second interval (time 70-90s) of two separate trials for a single subject. In both, the heavy dark line is the tracking reference signal and the finer line is the virtual pendulum position as controlled by the subject. The top graph is operating under hand and foot control with haptic feedback (condition 8) while the bottom one is using only foot control with haptic feedback (condition 4).

##### B. Analysis and Results

To assess tracking performance, the total root mean squared error for each trial was calculated. Thus each three minute trial generated a single performance variable by which to compare each trial run. An ANOVA was conducted with control condition type as the variable of inter-

est, blocking for both subject and replicate. The residuals of this test mostly follow a normal distribution except for one point, a first run for one subject of condition 8. Looking across all subjects within only this specific method, this one trial result was  $2.6 \times \text{IQR}$  (inner quartile range) beyond the factor mean, where typically greater than  $1.5 \times \text{IQR}$  is considered an outlier. Upon further examination, it was determined that this point was indeed an outlier and was set aside before further statistical analysis was performed. The ANOVA was repeated for all remaining data points. The subject, block, and method all showed statistical significance with  $p < 0.001$ ,  $0.016$ , and  $0.009$ , respectively.

Examining the data collected for all trials of all subjects (including the deemed outlier), the spread does not follow a normal distribution. Performing a Box-Cox Transformation with  $\lambda = -1$  and re-running the ANOVA with the previously described model, we obtain a statistical significance for the condition factor, with  $p < 0.025$ . Despite the transformation, that one point still appears to be an anomaly.

Paired t-tests were conducted on each pair of the four operating conditions. The general trend shows that the configuration with combined control and force feedback at the feet achieved the best results. However, only the comparison between foot control alone and combined control with haptic feedback demonstrated statistical significance. Figure 6 shows the box plot and confidence intervals of the mean RMS error for the trials, normalized by subject, and transformed by Box-Cox methods with a  $\lambda = -2$ .

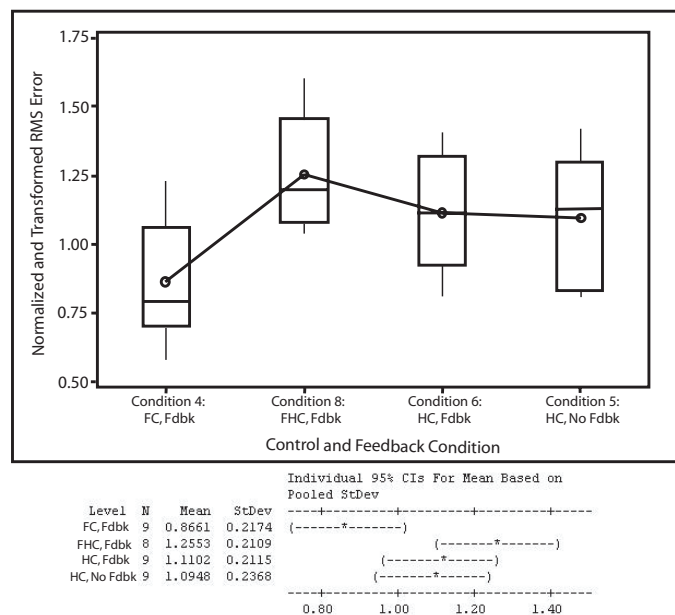

Fig. 6. The box plot for tracking performance versus manipulator condition shows that the method with combined hand and foot control (condition 8) yields superior performance to that of the feet acting alone (condition 4). Note that the data was normalized to account for subject variations and transformed with a power of  $\lambda = -2$  to generate a normal distribution. The 95% confidence intervals further illustrate a statistically significant difference between these two test conditions.

### C. Discussion

The results of this experiment suggest that the control efforts of the hand and feet may be combined to achieve superior performance than control effort applied by the feet alone. Although the combined control only slightly outperformed either of the two hand alone-methods, the most interesting comparison is to the feet-alone condition. The broad motivation for this experiment is completion and performance of a lower limb task by the lower limbs alone. Despite the lack of force feedback to the hand device, the input from it was not designed to be dominant over the feet input. Thus both effectors influenced the virtual pendulum equally. The appearance of improved performance when both inputs were used suggests that the two limbs were working together. Two subjects independently reported that the combined control condition felt easier; that their strategy evolved to use the hand for broad motions and the feet to damp the system oscillations.

The analysis of the data included eliminating a far outlying data point for the more detailed examination for trends. This rogue point was the first test by one of the subjects. It is possible that the poor performance during this trial was due to slow acclimation to the test equipment. Although the subject was given some time to practice in each mode, these two minute warmup periods may have been inadequate to eliminate learning effects. In future tests, it will be necessary to provide more complete training protocol to reduce the effects of learning trends.

### V. CONCLUSIONS

This paper presented a new idea concerning rehabilitation of individuals with incomplete paraplegia. We postulate that regenerating neural pathways and training affected lower limbs will be more effective if the subject is given some control over the process through a self-operated upper limb device. We also presented the design and construction of a single-axis actuated apparatus to be used in exploring this hypothesis. The primary features of this device include structural rigidity, dual-input options, and the flexibility of possible task development through the use of virtual environments. A preliminary experiment was conducted as a test run of the apparatus. Successful data collection and task completion shows that the designed device is capable of presenting a tracking task and effectively rendering the physical dynamics of the virtual system.

Before attempting to test if unaffected upper limbs can be used to retrain impaired lower limbs, it was necessary to determine if the upper and lower limbs could coordinate to provide superior performance in a single task. Therefore, the preliminary experiment also served to test if the hand can be used to assist the feet in a dynamic tracking task. The results show that tracking performance was improved by hand and foot manipulation of a single object as opposed to the feet alone. The effectiveness of this combined effort by two effectors could justify further exploration into the use of upper limbs to assist in retraining lower limbs.

One possible concern with the self-assist idea is that the hand controller might grow into a crutch for the patient

rather than a learning tool. Our intent is to use the self-assist robotics to aid the impaired limbs in the same manner as a therapist would during initial therapy training. We hypothesize that the patient will regain motor control over his lower limbs through practice, muscle development, and the strengthened neural connection between his upper and lower limbs. Once the subject attains proficiency at the given task, the control gains for the hand assistance can be gradually lowered until the lower limbs act completely independently.

Future work for this project will involve a more extensive analysis of the electromechanical system properties of the device, including a more advanced control scheme. In addition, the hand device will be updated with a motor to provide haptic feedback. Studies will include more work with healthy subjects to assess the effectiveness of the hand device as a training only tool in a complex stabilization or dynamic task. Eventually, we will train spinal cord injured subjects to look for improved motor control in the lower limbs.

#### AUTHORS' CONTRIBUTIONS

JWA co-conceived the hypothesis and participated in drafting the concept; DPF co-conceived the hypothesis and participated in drafting the concept; JWG co-conceived the hypothesis, participated in drafting the concept, and supervised lab operations; RBG co-conceived the hypothesis, co-designed the experiment, co-authored the manuscript, and supervised lab operations and device construction; KAD designed the experiment, designed and constructed the device, carried out testing and analysis, and co-authored the manuscript.

#### ACKNOWLEDGMENTS

The authors would like to give special thanks to Grace Lee for lab assistance. We also gratefully acknowledge the support of the University of Michigan Office of the Vice President for Research and the National Science Foundation under award numbers IIS:PECASE #0093290, BES-0347479, ECS-0322395, NIDA: DA017752 (JWA, PI), NIDA: DA15188 and NIMH: MH63649 (KC Berridge, PI).

#### REFERENCES

- [1] V. R. Edgerton, N. J. Tillakaratne, A. J. Bigbee, R. D. de Leon, and R. R. Roy, "Plasticity of the spinal neural circuitry after injury," *Annual Review of Neuroscience*, vol. 27, pp. 145–167, 2004.
- [2] C. M. Butefisch, "Plasticity in the human cerebral cortex: Lessons from the normal brain and from stroke," *Neuroscientist*, vol. 10, no. 2, pp. 163–173, 2004.
- [3] A. Wernig, A. Nanassy, and S. Muller, "Maintenance of locomotor abilities following laufband (treadmill) therapy in para- and tetraplegic persons: Follow-up studies," *Spinal Cord*, vol. 36, no. 11, pp. 744–749, 1998.
- [4] S. Hesse, H. Schmidt, C. Werner, and A. Bardeleben, "Upper and lower extremity robotic devices for rehabilitation and for studying motor control," *Curr Opin Neurol*, vol. 16, no. 6, pp. 705–710, 2003.
- [5] D. J. Reinkensmeyer, J. L. Emken, and S. C. Cramer, "Robotics, motor learning, and neurologic recovery," *Annual Review of Biomedical Engineering*, vol. 6, pp. 497–525, August 2004.
- [6] R. Riener, L. Lnenburger, and G. Colombo, "Cooperative strategies for robot-aided gait neuro-rehabilitation," (San Francisco), pp. 4822–4824, IEEE EMBS Conference, 2004.

- [7] C. Burgar, P. Lum, P. Shor, and H. Van der Loos, "Development of robots for rehabilitation therapy: the Palo Alto VA/Stanford experience," *Journal of Rehabilitation Research and Development*, vol. 36, pp. 663–673, 2000.
- [8] M. J. Johnson, *Embedded Corrective Force Cueing: A Force-Feedback Control Design to Optimize the Motivating Potential of Robot-Assisted Therapy Devices to Increase Bilateral Functioning in Hemiplegic Stroke Patients*. PhD thesis, Stanford University, September 2001.
- [9] H. J. Huang and D. P. Ferris, "Neural coupling between upper and lower limbs during recumbent stepping," *Journal of Applied Physiology*, vol. 97, pp. 1299–1308, June 2004.