

Multi-Period Production Capacity Planning for Integrated Product and Production System Design*

Emre Kazancioglu

*Institute for Manufacturing
University of Cambridge
Mill Lane, Cambridge CB2 1RX, UK
cek33@cam.ac.uk*

Kazuhiro Saitou

*Dept. of Mechanical Engineering
University of Michigan
Ann Arbor, MI 48109-2125, USA
kazu@umich.edu*

Abstract – *This paper presents a simulation-based method to aid multi-period production capacity planning by quantifying the trade-off between product quality and production cost. The product quality is estimated as the statistical variation from the target performances obtained from the output tolerances of the production machines that manufacture the components. The production cost is estimated as the total cost of owning and operating a production facility during the planning horizon. Given demand forecasts in future production periods, a multi-objective genetic algorithm searches for the optimal types and quantity of the production machines to be purchased during each period, which simultaneously maximize the product quality and minimize the production cost during the entire planning horizon. Case studies on automotive valvetrain production are presented as a demonstration.*

Index Terms – *Capacity Planning, Tolerance Allocation, Product-Process Design, Genetic Algorithms*

I. INTRODUCTION

With the increased number of players competing in a global market, numerous substitute products became available for the consumers to choose from. It is crucially important for manufacturing firms to be able to accommodate changes in market demand and product requirements in a timely manner, by optimally designing their production facilities. Lack of accurate long-range forecasts of demand and production requirements drives firms to formulate short-sighted strategic adjustments as a reaction to emerging market realities, which compromises profits since:

- Firms making incremental changes in production capacity cannot take advantage of scale economies.
- Time lag between the placing a purchase order and the delivery of machine tools hinders timely adjustments.
- Allocating extra capacity early or maintaining over-capacity in anticipation of future demand increase may be economically advantageous. Short-sighted planning cannot accommodate this option.

Despite the increased uncertainty in long-term demand forecasts, it is often desirable to consider multiple

production periods in order to meet fluctuating demand with minimum capital and operating costs.

On the other hand, if cost is reduced at the expense of quality, the brand image may easily be damaged and future demand may be jeopardized. However increasing product quality by investing on higher quality machinery drives the cost of the product up. For smarter capacity planning decisions, therefore, it is important to understand the trade-off between the capital and operating costs incurred by the expansion/retraction of production capacity and the resulting changes in product quality.

To address this issue in a practical framework, this paper presents a simulation-based method to aid multi-period production capacity planning by quantifying the trade-off between product quality and production cost. Given market demand for multiple production periods, the method determines the types and quantity of production machines to be purchased during each period, which maximize the product quality and minimize the production cost. As our first attempt, future demand is assumed as given as a deterministic forecast. The product quality is estimated as the statistical variation from the target performances obtained from the output tolerances of the machines that manufacture the components, via Monte Carlo simulation. The production cost is estimated as the total cost of owning and operating a production facility during the planning horizon. Case studies on automotive valvetrain production are presented as a demonstration.

II. RELATED WORK

Capacity planning involves analysis and decisions to balance capacity at a production or service point with demand from customers. Once capital expenditure has been made, it cannot be recovered entirely since salvage values are well below the original costs [1]. Therefore, bearing over-capacity and under-capacity may prove to be more cost efficient in some production periods. Extensive research has been done on developing tools to make effective capacity planning decisions. Ref. [2] presents a survey covering a broad spectrum of capacity expansion problems, listing modeling approaches, algorithmic solutions and applications. A general model that considers replacement of capacity as well as expansion and disposal, together with scale economy effects assuming deterministic technological changes is developed in [3]. Focusing on the problem of a firm that must satisfy a monotone increasing demand over time, ref. [4] aims to

* This work is partially supported by the US Army TACOM and the GM Collaborative Research Laboratory at the University of Michigan through the Dual Use Science and Technology Program on The Concurrent Design of Next-Generation Powertrains, Manufacturing Process and Materials.

minimize the cost of investing in new capacity, production, inventory and shortage over a finite horizon. Existence of uncertainty influences the investment, production and pricing decision of firms and thus capacity expansion models need to take uncertainty into consideration [5]. Stochastic programming [6] and finite-horizon Markov decision models [7] are two methods used to model stochastic problems. Ref. [8] studies the discrete-time capacity expansion problem involving multiple product families, multiple machine types and non-stationary stochastic demand. An important observation in the paper is that the long procurement time requires the capacity expansion decisions to be made based on the demand forecasts 2-3 years into the future, which are prone to be erroneous. Ref. [9] presents an optimal solution to the capacity management problem in Reconfigurable Machining Systems [10] using stochastic market demand with time delay between the time capacity change is ordered and the time it is delivered, based on the Markov Decision Theory. Ref. [11] presents a model to determine optimal investment strategies for a manufacturing firm that employs multiple resources to market several products to an uncertain demand.

Integrated or concurrent design of products and production systems has been studied to eliminate inefficiencies resulting from the traditional sequential design framework. Some studies focus on the product development side while considering production related criteria. Others focus on the production system design and incorporate product related criteria in the formulation.

Ref. [12] discusses a systematic method for evaluating the overall performance of different machining system configurations with respect to productivity, quality, scalability and convertibility. Ref. [13] presents a methodology for simultaneously selecting optimal machining process parameters and tolerance specifications for multi-stage machining systems. Ref. [14] combines the production-inventory and capacity expansion problem by modeling it as a linear, integer problem. Ref. [15] develops a model to simultaneously determine the optimum capacity level, production schedule and inventory levels given a deterministic demand forecast. Ref. [16] develops a formulation for machine cell formation with reliability considerations in cellular manufacturing systems. Ref. [17] attempts to integrate design and process planning by assessing manufacturability, and estimating the cost of the conceptual design early at the design stage. Ref. [18] develops a quantitative method to optimize part design, tolerancing, and production & inventory control concurrently. Ref. [19] modifies the Taguchi method and the response surface methodology (RSM) to fit a multicriteria framework in order to design and control a cellular manufacturing system in a robust and optimal fashion.

Despite extensive research, the issue of product quality resulting from the change in production facility has not been addressed properly. In addition, most capacity planning literature use simplified analytical models of the production process and does not provide generic tools that

have applicability in a wide array of problems. The presented method, on the other hand, provides a generic approach by utilizing multi-objective optimization along with a simulation-based analysis of the production process and product performance. This allows the examination of the tradeoffs between production cost and product quality in more realistic scenarios.

III. METHOD

The method developed for the analysis and design of multi-period capacity planning problem is illustrated in Fig. 1. Given demand forecasts for the planning horizon and the capacity plan (selection of the types and quantity of production machines for each period), the production system model simulates the production process until steady state, and calculates the capital and operating costs for the whole planning horizon. In addition, the dimensional variations of components of the parts collected in the finished goods inventory (FGI) are tracked during the production simulation. The dimensional variations of components are used as an input to the product model, which calculates the quality of the end product as the statistical variation of product performance via Monte Carlo simulation. Based on the production cost and the product quality, a multi-objective optimizer determines the Pareto-optimal selections of the types and quantity of machines in the production system during each period in the planning horizon.

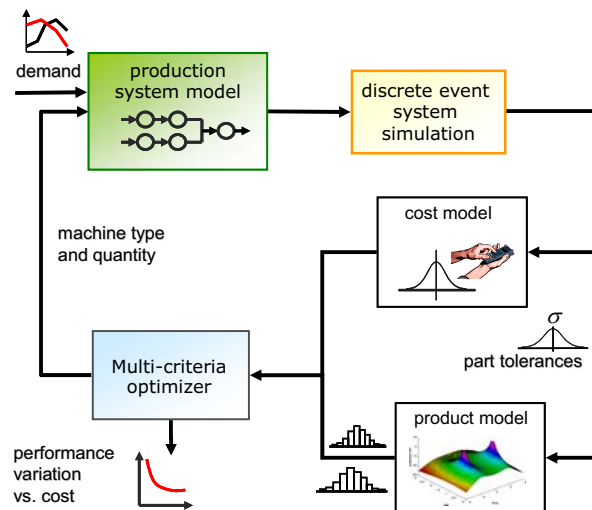

Fig. 1 Overview of the method

A. Product and Production System Models

The product model takes a set of product parameters (e.g., component dimensions) as an input and calculates the product performances. In the present study, the quality of the product is estimated as the statistical variation of the product performance due to the variations of the product parameters, and is calculated by Monte Carlo simulation of the product performances with samples input product parameters. The variation of a product parameter is assumed as normally distributed with mean being nominal value and standard deviation being 1/3 of the tolerance

(accuracy) of the types of machines used to process the parameter, and accordingly sampled during the Monte Carlo simulation.

We consider a class of production systems which are comprised of cells of machines each performing one manufacturing operation, and part buffers between each cell. Fig. 2 shows an example with three cells and five buffers. As illustrated in Fig. 2, each cell consists of one or more machines. While machines in a cell perform the same manufacturing operation which affects one or more product parameters, they can be of different types. A type of machines is defined based on the following information:

- manufacturing operation
- process time (mean and standard deviation)
- tolerances of the relevant product parameters
- operating cost
- machine price

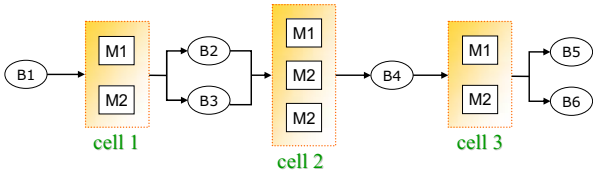

Fig. 2 Example production system

During the optimization process, the topology of a production system remains constant, whereas the types and quantity of machines in each cell are altered among the available choices, in order to maximize the product quality and minimize the production cost.

For a given selection of machine types and quantities, the operation of the production facility is simulated by a discrete event simulation [20]. The process time of each machine type is assumed as normally distributed with given mean and standard deviation, and accordingly sampled during the simulation. After simulating production for the periods with forecasted demands, the total amount of production and the utilization of each machine for each period are calculated, in order to estimate the operating cost as demonstrated in detail in the following section. In addition, the types of machines in each cell which are used to manufacture each product are recorded during the simulation, in order to estimate the quality of the finished product as described in the next section.

B. Design Variables and Constraints

The design variables are the types and number of machines in each cell in the production system at each period. It can be represented as the number of machines of type k in cell j during period i :

$$x_{ijk} \in \mathbf{Z}, x_{ijk} \geq 0, i = 1, \dots, n, j = 1, \dots, m, k = 1, \dots, l_j \quad (1)$$

where n is the number of periods, m is the number of cells, l_j is the number of available machine types at cell j .

There must be at least one machine in a cell, which imposes the following constraint:

$$\sum_{k=1}^{l_j} x_{ijk} \geq 1; \quad i = 1, \dots, n, j = 1, \dots, m \quad (2)$$

C. Objective Functions

The first objective function is the measure of product quality defined as the sum of the coefficient of variations of the performance criteria:

$$f_1 = \sum_{i=1}^{n_c} \frac{\sigma_i}{\mu_i} \quad (3)$$

where n_c is the number of performance criteria, μ_i and σ_i are the mean and standard deviation of the i -th performance criterion obtained by Monte Carlo simulation of product model. Alternatively, a weighted sum of σ_i can be used.

The second objective function is the estimation of the capital and operating costs of production, defined as the sum of the annual equivalent of capital investment cost ($AECC$), operating cost ($AEOC$), backorder cost ($AEBC$), and holding cost ($AEHC$) for all periods [21].

$$f_2 = AECC + AEOC + AEBC + AEHC \quad (4)$$

$$AECC = \varepsilon \sum_{i=1}^n \delta_i \{(1 + \eta) IC_i + SC_i\}$$

$$AEOC = \varepsilon \sum_{i=1}^n \delta_i OC_i \quad (5)$$

$$AEBC = \varepsilon \sum_{i=1}^n \delta_i BC_i$$

$$AEHC = \varepsilon \sum_{i=1}^n \delta_i HC_i$$

where η is cost of capital of the project, ε is the capital recovery factor for equal payments during n periods, and δ_i is the discount factor for the present value of future cash flows [21].

The capital investment cost IC_i of period i is the sum of the cost of machines purchased at the beginning of the period. Assuming there is no machine available at the beginning of period 1 :

$$IC_1 = \sum_{j=1}^m \sum_{k=1}^{l_j} c_{jk} x_{1jk} \quad (6)$$

For the subsequent periods, the cost incurs only when new machines are purchased:

$$IC_i = \sum_{j=1}^m \sum_{k=1}^{l_j} c_{jk} \times \max(0, x_{ijk} - x_{(i-1),jk}); \quad i = 2, \dots, n \quad (7)$$

where c_{jk} is the price of machine of type k in cell j .

The purchased machines can be sold at their market value at the end of period i to if there is excess capacity for the next period, which can be represented as a negative salvage cost SC_i :

$$SC_i = - \sum_{j=1}^m \sum_{k=1}^{l_j} \sum_{o \in O_j} c_{jk} \alpha^{A_{jko}}; \quad i = 1, \dots, n-1 \quad (8)$$

where α is the yearly percentage decrease in the market value of a machine, A_{ijk} is the age of the o -th machine of type k in cell j in period i . O_i is a set of $\max(0, x_{(i-1)jk} - x_{ijk})$ indices of machines of type k in cell j sold after period i . There are no priorities set among machines as to which one is to be sold first. This is done intentionally since depending on the rate of market value depreciation and the rate of increase in the operating cost, fixed policies such as selling the oldest machines may be suboptimal. At the end of period n , all purchased machines are assumed to be sold:

$$SC_n = -\sum_{j=1}^m \sum_{k=1}^{l_j} \sum_{o=1}^{x_{ijk}} c_{jk} \alpha^{A_{ijk}} \quad (9)$$

However, depending on the type of a production system and the range of the periods considered, this assumption can be replaced with a more suitable one.

The operating cost OC_i of period i is the sum of the product of the machine utilization, operating cost, and total operation time in a period:

$$OC_i = \sum_{j=1}^m \sum_{k=1}^{l_j} \sum_{o=1}^{x_{ijk}} u_{ijk} \times oc_{jk} (1 + \lambda)^{A_{ijk}} \times t_i \quad (10)$$

where u_{ijk} is the utilization of the o -th machine of type k in cell j in period i , oc_{jk} is the operation cost of machine type k in cell j , λ is the yearly percentage increase in the operation cost, and t_i is the operating time. The values of u_{ijk} and t_i are provided by the discrete event simulation of the production process.

The back order cost BC_i penalizes poor customer service due to unmet demand by a cost proportional to the amount of the demand that cannot be filled:

$$BC_i = c_b \times \max(0, d_i - n_i) \quad (11)$$

where c_b is the back order cost. Similarly, the excess production incurs the inventory holding cost HC_i :

$$HC_i = c_h \times \max(0, n_i - d_i) \quad (12)$$

where c_h is the holding cost.

D. Optimization Problem

The problem can be formulated as the follows:

$$\begin{aligned} & \min \{f_1, f_2\} \\ & \text{s.t. } \sum_{k=1}^{l_j} x_{ijk} \geq 1; \quad i = 1, \dots, n, j = 1, \dots, m \\ & \quad x_{ijk} \in \mathbf{Z}, x_{ijk} \geq 0, \quad i = 1, \dots, n, j = 1, \dots, m, k = 1, \dots, l_j \end{aligned} \quad (13)$$

In the following case study, the problem is solved using a multi-objective genetic algorithm (MOGA) [22].

IV. CASE STUDIES

A case study is conducted on an automotive valvetrain production system. The main function of the valvetrain (Fig. 3 (a)) is to control the flow of intake and exhaust gases with linear motion of valves, which is obtained by

transforming the rotational motion of camshaft. The case study focuses on the production of valve stems and camshafts, and their effects on the horsepower, torque, and fuel consumption of the engine.

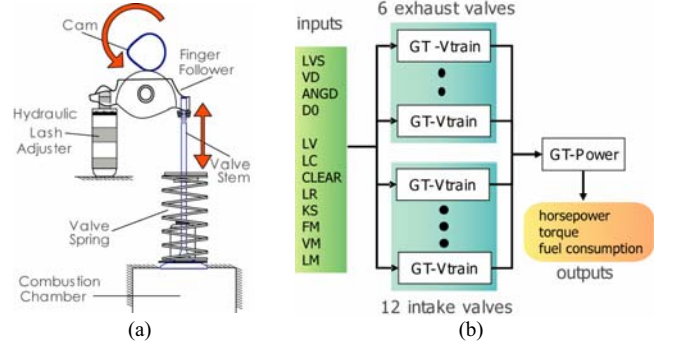

Fig. 3 (a) Valvetrain; (b) Integrated Valvetrain-Engine Simulation [23]

A. Product and Production System Models

The product model is a surrogate model (Artificial Neural Network) of an integrated valvetrain-engine simulation model of Ford Duratec 2.5L V6 SI engine, developed using commercial software GT-Vtrain and GT-Power [23] (Fig. 3 (b)). The inputs are the selective dimensions of valves and cams: valve stem length (LVS), valve stem diameter (VD), cam lift duration angle (ANGD), and cam lift beginning angle (D0). The outputs are the horsepower, torque, and fuel consumption of the engine.

Fig. 4 shows the cell configuration of the valvetrain production system with an example capacity allocation. It produces valve stems and cam shafts, and assembles them with engine blocks. The line for valve stems consists of cells 1 and 2 for machining LVS and VD, respectively. The line for camshafts consists of cell 3 for grinding cam lobes (controls ANGD) and cell 4 for assembling the finished cam lobes to camshaft (controls D0).

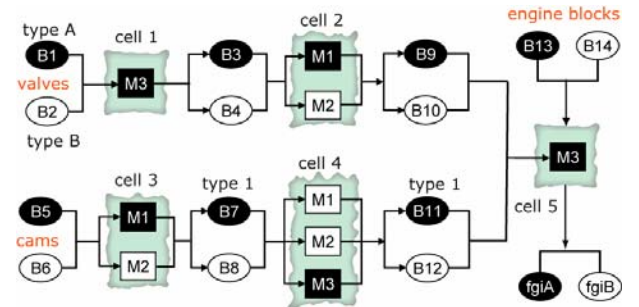

Fig. 4 Valvetrain Production System

Table 1 Machine data of valvetrain production system

	Cell 1		Cell 2		Cell 3		Cell 4		Cell 5	
machine type	M1	M2	M1	M1	M2	M1	M1	M2	M1	M2
dimension	VD	VD	LVS	LVS	ANGD	ANGD	D0	D0	N/A	N/A
μ process time [min]	40	50	20	30	40	70	40	70	4	6
σ process time [min]	0.5	1	0.4	0.6	0.6	0.75	0.8	1	0.5	0.5
operating cost [\$/h]	30	40	15	50	100	50	75	20	50	100
machine price [K\$]	200	270	150	200	250	400	210	445	60	60
tolerance	0.01	0.005	0.03	0.01	0.004	0.001	0.5	0.15	N/A	N/A

The type of machines available for the production system is listed in Table 1. The processing times of the machine tools correspond to the time it takes to process one batch of parts, which is 24 for both the valves and the cam lobes (4 cam shafts, 6 cam lobes on each).

B. Optimization Problem

Three, one-year periods ($n = 3$) are considered as a horizon of the capacity planning. The quality objective f_1 is defined as the sum of the coefficient of variation of horsepower, torque and fuel consumption, obtained by the Monte Carlo simulation with the neural network model. Table 2 shows the market demand for the 3 periods (3 years), representing the situation where demand falls in the 2nd period and picks up again in the 3rd period.

It is assumed the production stops as soon as the demand is met at each period (a no back-order, no-inventory policy). Also, the input buffers providing raw materials never starve. The cost of capital η , depreciation rate of machines α , and rate of increase operation cost λ are assumed 10%, 50%, and 10% per year, respectively.

Table 2 Market demand for product

	period 1	period 2	period 3
demand [units]	18,000	10,000	20,000

C. Results

To demonstrate the benefit of the multi-period planning, mixing multiple machine types in a cell, and the quantification of quality-cost trade off, the results are presented for the following four cases:

- **Case 1. Single-period, single machine type, minimum cost planning:** Three capacity planning problems for the three periods are separately solved considering only cost objective f_2 using only machine type 1 for each cell.
- **Case 2. Multi-period, single machine type, minimum cost planning:** One capacity planning problem considering all three periods is solved considering only cost objective f_2 using only machine type 1 for each cell.
- **Case 3. Multi-period, single machine type, minimum cost-maximum quality planning:** One capacity planning problem considering all three periods is solved considering both quality objective f_1 and cost objective f_2 using only machine type 1 for each cell.
- **Case 4. Multi-period, multi-machine type, minimum cost-maximum quality planning:** One capacity planning problem considering all three periods is solved considering both quality objective f_1 and cost objective f_2 using both machine types 1 and 2 for each cell.

Table 3 Parameters for Genetic Algorithm

	Case 1	Case 2	Case 3	Case 4
Mutation prob.	0.01	0.01	0.01	0.01
Crossover prob.	0.9	0.9	0.9	0.9
Population size	45	120	120	120
Max. # of generations	30	60	80	100

Table 3 shows the parameters of multi-objective genetic algorithm used to obtain the results. Number of generations is adjusted in an attempt to be as fair as possible when making comparisons between the cases.

Table 4 shows the objective function values (minimum cost) for Cases 1 and 2 and Tables 9 and 10 shows their machine allocations, respectively.

Table 4 Cost results for Cases 1 and 2

	Case 1	Case 2
AEOC	\$ 1,357,813	\$ 1,324,121
AECC	\$ 1,583,009	\$ 1,406,090
AEBC	\$ 0	\$ 0
f_2	\$ 2,940,957	\$ 2,730,211

Table 5 Optimal machine allocation for Case 1

	Cell 1		Cell 2		Cell 3		Cell 4		Cell 5	
	M1	M2	M1	M2	M1	M2	M1	M2	M1	M2
P1	5	-	6	-	5	-	6	-	5	-
P2	3	-	2	-	3	-	3	-	3	-
P3	6	-	5	-	5	-	5	-	5	-

Table 6 Optimal machine allocation for Case 2

	Cell 1		Cell 2		Cell 3		Cell 4		Cell 5	
	M1	M2	M1	M2	M1	M2	M1	M2	M1	M2
P1	5	-	6	-	5	-	6	-	5	-
P2	4	-	4	-	4	-	4	-	4	-
P3	6	-	5	-	5	-	5	-	5	-

In Case 1, an increase in the demand in the third period is not anticipated, and a capacity retraction is carried out in the second period due to reduced demand. In Case 2, on the other hand, the demand information about the third period is available and it is more cost effective to keep the excess capacity in the second period in comparison to retracting capacity in the second period and then to expand it later again in the third period. The annual equivalent cost of Case 2 is approximately \$200K less than that of Case 1. This adds up to approximately \$600K of cost savings over a three year planning horizon.

Fig. 6 shows Pareto optimal solutions from multiple runs of Cases 3 and 4, indicating quality-cost trade-off in both cases. The square on the bottom right corner of Fig. 6 shows the Case 2 optimum result. As expected, optimum value for Case 2 coincides with the results of the Cases 3 and 4 on the low-quality, low-total cost part of the Pareto front. Option 1 in Fig. 6 tells cost increases by 20% for 10% quality improvement over Case 2 optimum. Table 7 shows the capacity plan for Option 1. Since consumers may be willing to pay the price premium for a higher quality product, this trade-off curve, along with the information on the price elasticity of the consumers, is very valuable to optimally position the products to maximize profit.

A comparison of the results from Cases 3 and 4 reveals the benefit of allowing the use of mixed machine types in the production plan for attaining solutions that have better quality-cost characteristic. By using Option 4 (Case 4 results), it is possible to attain the same level of production quality as in Option 3 (Case 3 results) without having to pay more. Similarly, it is possible to have the same production quality of Option 2 (Case 3) by actually paying less. The machine allocations for Options 2, 3 and 4 are shown in Tables 7, 8 and 9 respectively.

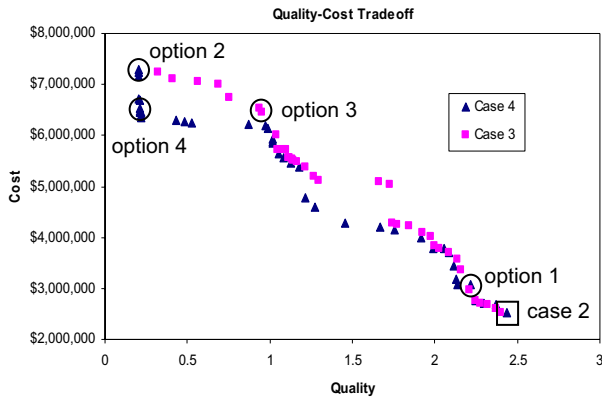

Fig. 6 Quality-cost tradeoff curve, Pareto optimal results

Table 7 Optimal machine allocation for Option 1

	Cell 1		Cell 2		Cell 3		Cell 4		Cell 5	
	M1	M2	M1	M2	M1	M2	M1	M2	M1	M2
P1	0	5	5	0	4	0	4	0	4	0
P2	0	5	2	0	4	0	4	0	3	0
P3	0	6	4	0	4	0	4	0	4	0

Table 8 Optimal machine allocation for Option 2

	Cell 1		Cell 2		Cell 3		Cell 4		Cell 5	
	M1	M2	M1	M2	M1	M2	M1	M2	M1	M2
P1	0	6	0	5	0	7	0	7	0	7
P2	0	3	0	2	0	5	0	5	0	3
P3	0	6	0	6	0	7	0	7	0	6

Table 9 Optimal machine allocation for Option 3

	Cell 1		Cell 2		Cell 3		Cell 4		Cell 5	
	M1	M2	M1	M2	M1	M2	M1	M2	M1	M2
P1	0	6	0	5	6	0	0	7	0	6
P2	0	5	0	5	0	5	0	7	0	5
P3	0	6	0	5	0	7	0	7	0	6

Table 10 Optimal machine allocation for Option 4

	Cell 1		Cell 2		Cell 3		Cell 4		Cell 5	
	M1	M2	M1	M2	M1	M2	M1	M2	M1	M2
P1	1	4	2	2	0	7	0	7	2	2
P2	1	4	2	2	0	7	0	7	2	2
P3	1	4	2	2	0	7	0	7	2	2

V. SUMMARY AND FUTURE WORK

This paper presented an optimization-based method for capacity planning of production facilities considering the demand changes in multiple production periods and the trade-offs between the product quality and production cost. The method is then applied to a capacity planning problem in an automotive valvetrain production. The results demonstrated the effectiveness of considering multi-period demand forecast, quantitative quality-cost trade-off, and use of multiple machine types within a cell. Future work will investigate the capacity planning problem in multi-product production lines under stochastic demands.

ACKNOWLEDGMENT

The authors acknowledge Mr. Karim Hamza for his contribution to the development of the MOGA code.

REFERENCES

[1] Giglio, R., "Stochastic capacity models," *Manage Sci*, vol. 17, no. 3, 1970, pp. 174-184.

[2] Luss, H., "Operations research and capacity expansion problems: a survey," *Oper Res*, vol. 30, no. 5, 1982, pp. 907-947.

[3] Rajagopalan, S., "Capacity expansion and equipment replacement: a unified approach," *Oper Res*, vol. 46, no 6, 1998, pp 846-857.

[4] Sethi, S., Taksar, M., and Zhang, Q., "Hierarchical capacity expansion and production planning decisions in stochastic manufacturing systems," *J. Oper Manage*, vol. 12, 1995, pp. 331-352

[5] Paraskevopoulos, D., Karakitsos, E., and Rustem, B., "Robust capacity planning under uncertainty," *Manage Sci* vol. 37, no. 7, 1991, pp. 787-800.

[6] Bienstock, D., and Shapiro, J., "Optimizing resource acquisition decisions by stochastic programming," *Manage Sci*, vol. 34, no. 2, 1988, pp. 215-229.

[7] Bhatnagar, S., Fernandez-Gaucherand, E., Fu, M., He, Y., and Marcus, S., "A Markov decision process model for capacity expansion and allocation," *Conf. Decision & Control*, Phoenix, Arizona, 1999.

[8] Roundy, R., Zhang, F., Cakanyildirim, M., and Huh, W., "Optimal capacity expansion for multi-product, multi-machine manufacturing with stochastic demand," *IIE Trans.*, vol. 36, no. 1, 2004, pp. 23-36.

[9] Asl, F., and Ulsoy, G., "Capacity management in reconfigurable manufacturing systems with stochastic market demand," *ASME Int Mechanical Engineering Congress and Exposition*, New Orleans, Louisiana, 2002, IMECE2002-MED-32872

[10] Mehrabi, M., Ulsoy, G., and Koren, Y., "Reconfigurable manufacturing systems: key to future manufacturing," *J Intell Manuf*, vol. 11, no. 4, 2000, pp. 403-419.

[11] Harrison, J. and Van Mieghem, J., "Multi-resource investment strategies: operational hedging under demand uncertainty," *Euro J Oper Res*, vol. 113, 1999, pp. 17-29.

[12] Zhong, W., Maier-Speredelozzi, V., Bratzel, A., Yang, S., and Hu, S., "Performance analysis of machining systems with different configurations", *USA-Japan Symposium on Flexible Automation*, Ann Arbor, MI, 2000.

[13] Zhong, W., Hu, S., and Bingham, D., "Selecting process parameters and machine tolerances for optimal system performance," *International Conf. Frontiers of Design and Manufacturing*, Dalian, China, 2002.

[14] Barchi, R., Sparrow, F., and Vemuganti, R., "Production, inventory and capacity expansion scheduling with integer variables," *Manage Sci*, vol. 21, no. 7, 1975, pp. 783-793.

[15] Bradley, J., and Arntzen, B., "Simultaneous planning of production, capacity, and inventory in seasonal demand environments," *Oper Res*, vol. 47, no. 6, 1999, pp. 795-806.

[16] He, D., and Adamyan, A., "Multidisciplinary machine cell formation for design of cellular manufacturing systems," *ASME Design Engineering Technical Conf*, Las Vegas, NV, 1999, DETC99/DFM-8928.

[17] Feng, S., and Song, E., "Information modeling of conceptual process planning integrated with conceptual design," *ASME Design Engineering Technical Conf*, Baltimore, MD, 2000, DETC2000/DFM-14009.

[18] Wei, Y., and Thornton, A., "Concurrent design for optimum production performance," *ASME Design Engineering Technical Conf*, Montreal, Canada, 2002, DETC2002/DFM-34163.

[19] Shang, J., and Tadikamalla, P., "Multicriteria design and control of a cellular manufacturing system through simulation and optimization," *Int J Prod Res*, vol. 36, no. 6, 1998, pp. 1515-1528.

[20] Banks, J., Carson, J., and Nelson, B., *Discrete-Event System Simulation*, 2nd ed., Prentice Hall, 1996.

[21] Park, C., *Contemporary Engineering Economics*, 3rd ed., Prentice Hall, 2001.

[22] Coello, C., van Veldhuizen, D., and Lamont, G., *Evolutionary Algorithms for Solving Multi-Objective Problems*, Kluwer Academic/Plenum Publishers, 2002.

[23] Kazancioglu, E., Wu, G., Ko, J., Bohac, S., Filipi, Z., Hu, S., Assanis, D., and Saitou, K., "Robust optimization of an automotive valvetrain using multiobjective genetic algorithm," *ASME Design Engineering Technical Conf*, Chicago, IL 2003, DETC2003/DAC-48714.