

Opportunities with polarized Drell-Yan at Fermilab

Wolfgang Lorenzon

UNIVERSITY OF MICHIGAN

COMPASS Beyond 2020

(21-March-2016)

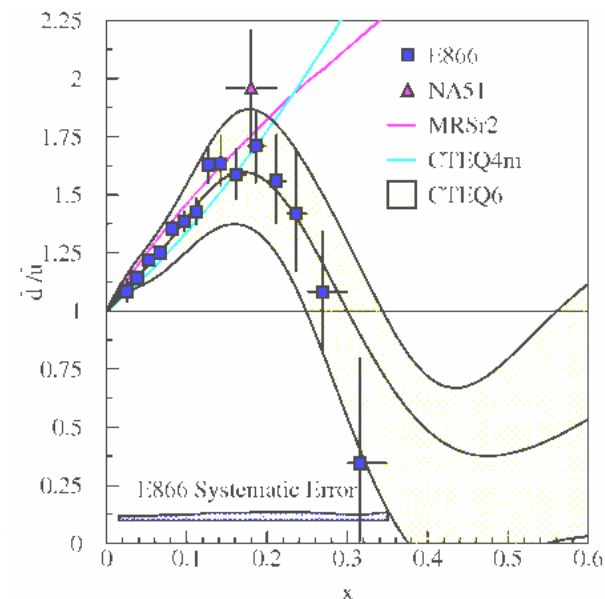
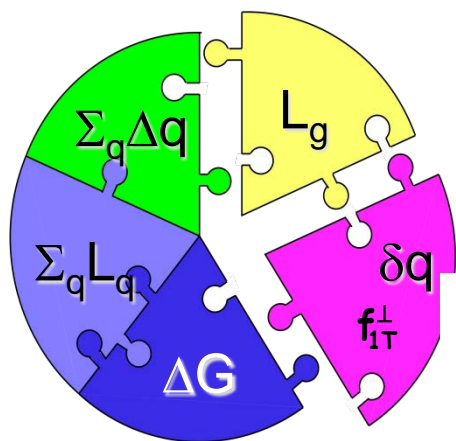

Dark energy

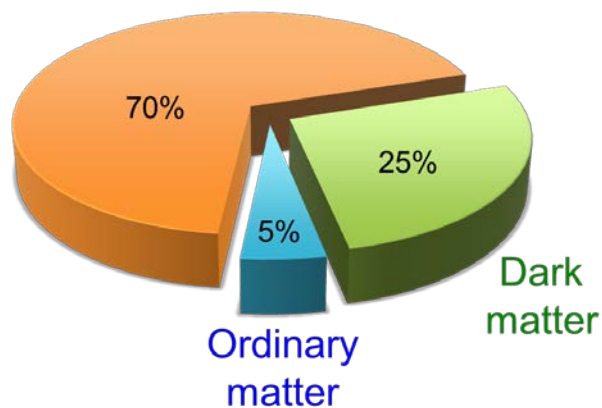

$$f_{1T}^{\perp} \Big|_{DIS} = - f_{1T}^{\perp} \Big|_{DY}$$

This work is supported by



Current and Future D-Y Program at FNAL



Unpolarized Beam and Target w/ SeaQuest detector

- **E-906:** 120 GeV p from Main Injector on $\text{LH}_2, \text{LD}_2, \text{C}, \text{Fe}, \text{W}$ targets → **high-x Drell-Yan**
- Science data started in March 2014
 - run for 3 yrs
 - preview

Polarized Beam and/or Target w/ SeaQuest detector

- **high-luminosity** facility for **polarized Drell-Yan**
- **E-1039:** SeaQuest w/ pol NH_3 target (2018-2019)
 - probe sea quark distributions
- **E-1027:** pol p beam on (un)pol tgt (2020-2021?)
 - **Sivers sign change** (valence quark)

SeaQuest Experiment

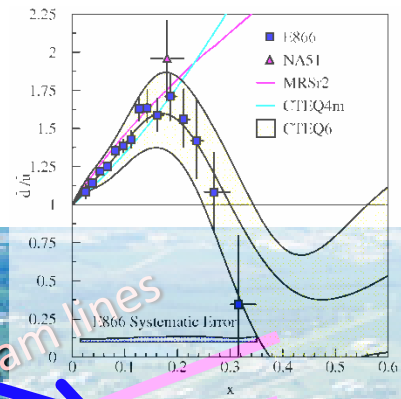

Fixed Target Beam Lines

Tevatron 800 GeV

Main Injector 120 GeV

SeaQuest Spectrometer

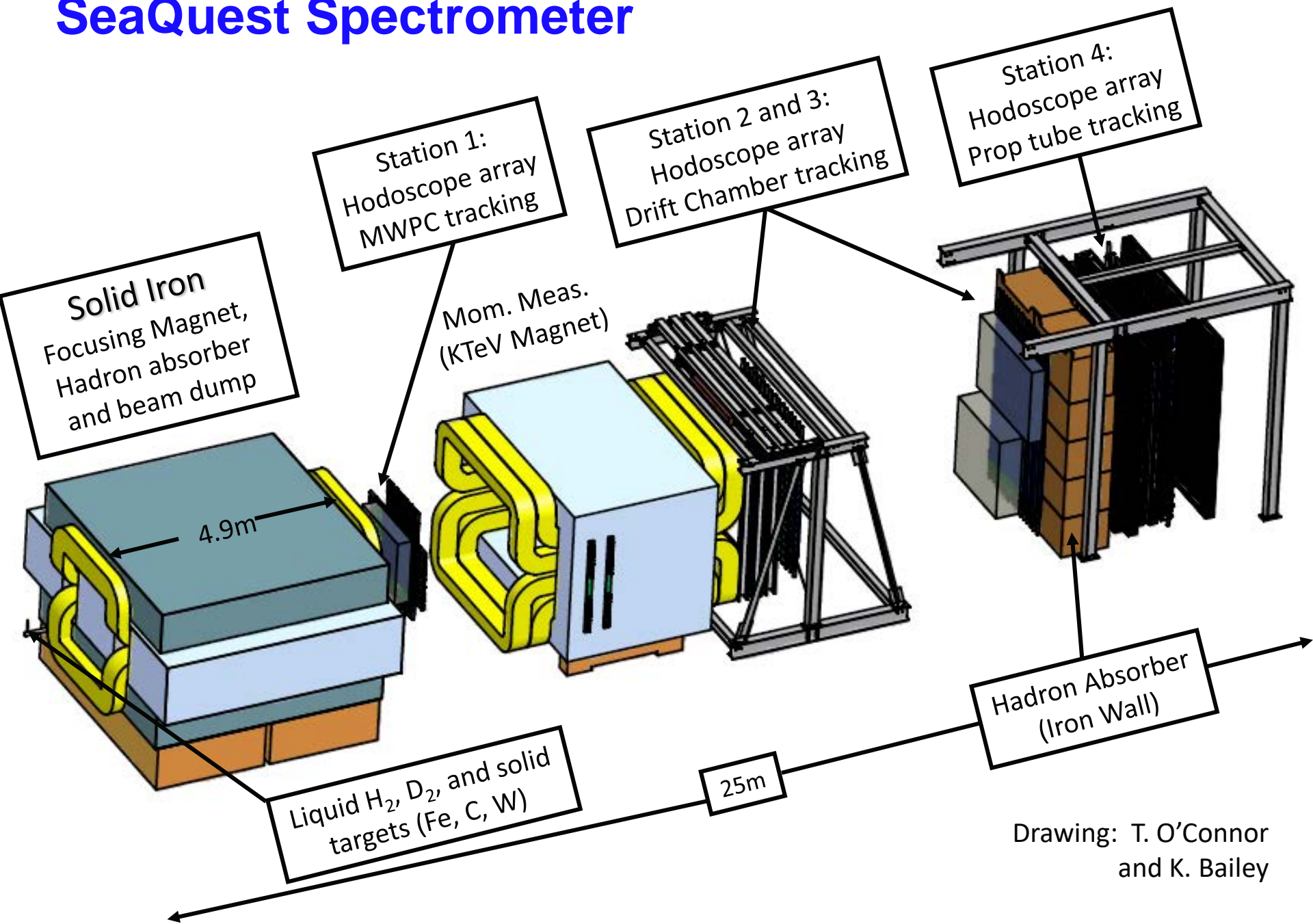

Drawing: T. O'Connor
and K. Bailey

Data from FY2014: Target-Dump Separation

- Entire beam interacts upstream of SeaQuest Spectrometer
- Pointing resolution fairly poor along beam axis

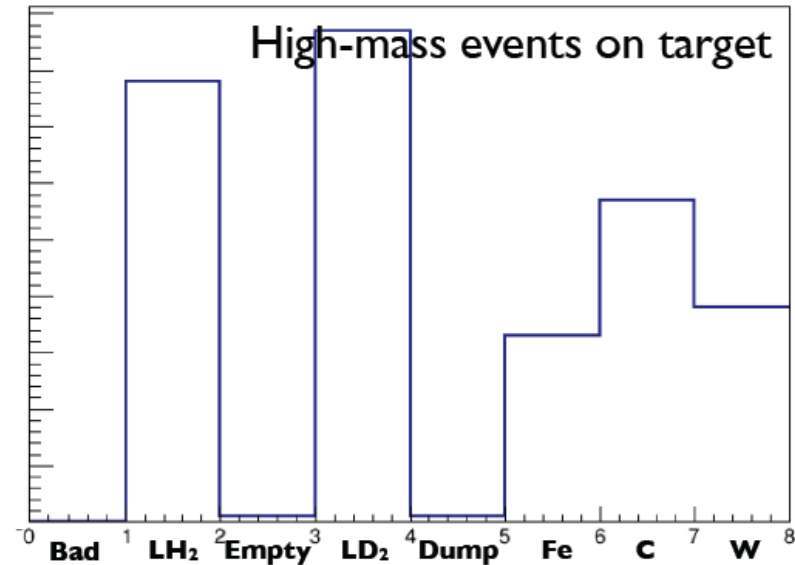
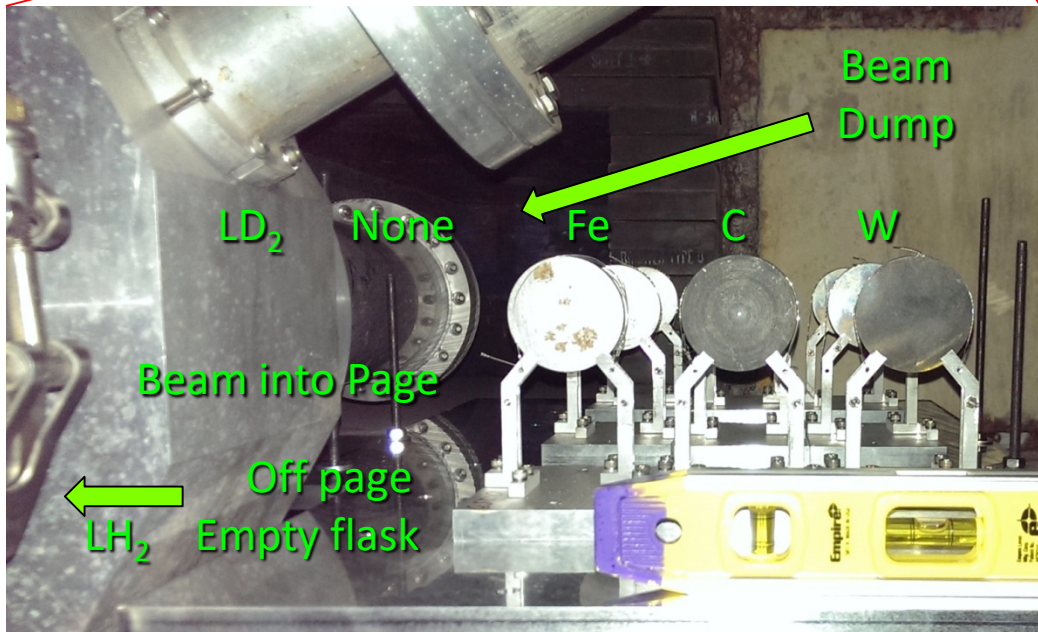
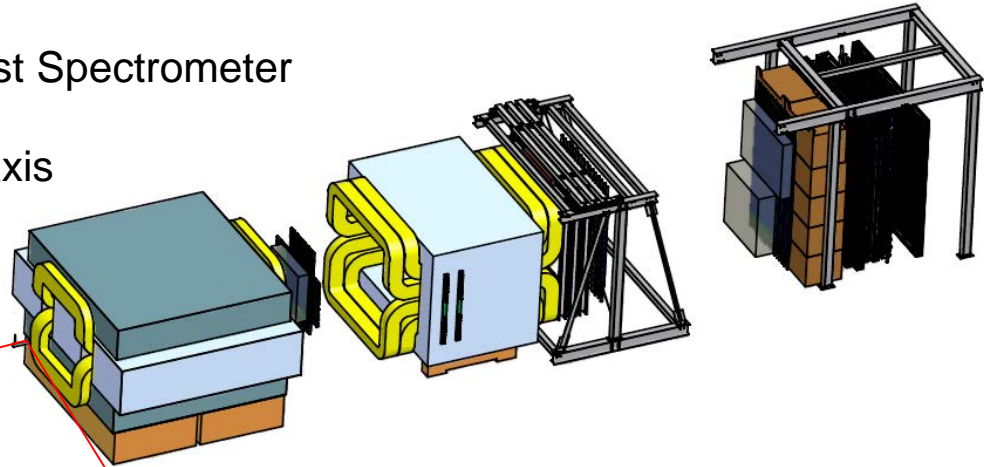

Data From FY2014

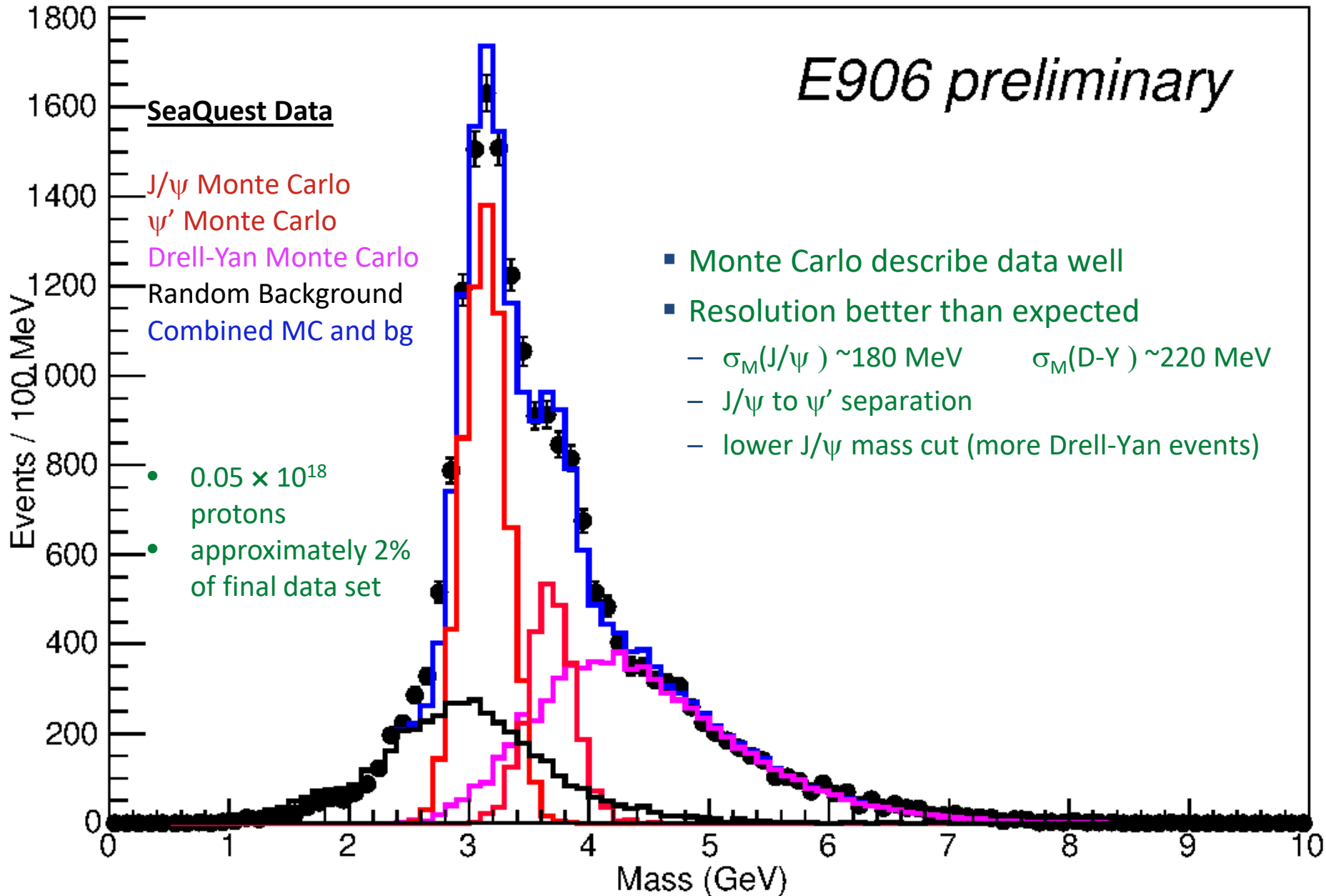

SeaQuest Cross Section Ratio (Preview)

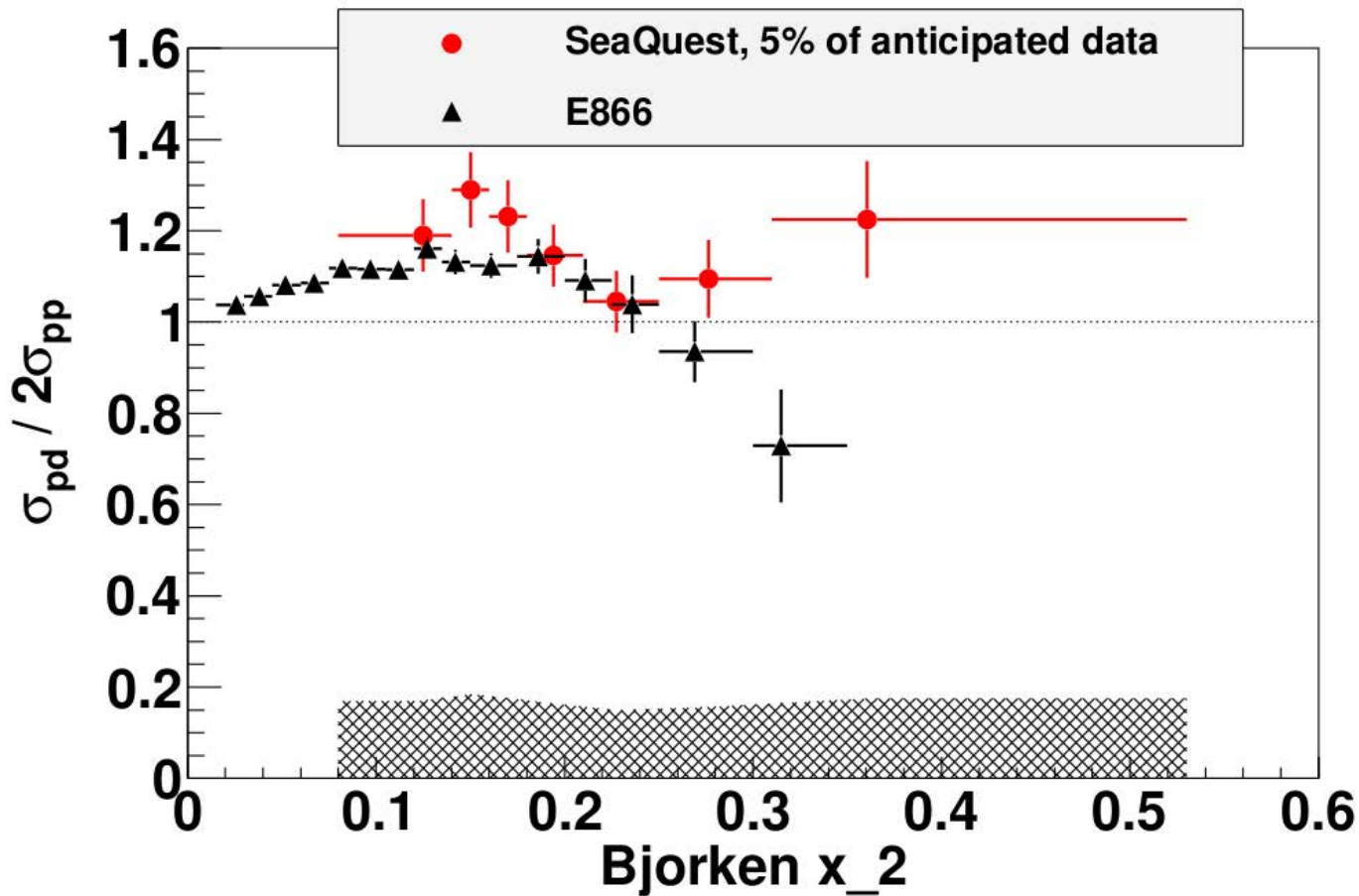

- data presented by Bryan Kerns at April 2015 APS
- **Caution: rate-dependence not included** (still being studied)

SeaQuest Leading Order extraction (Preview)

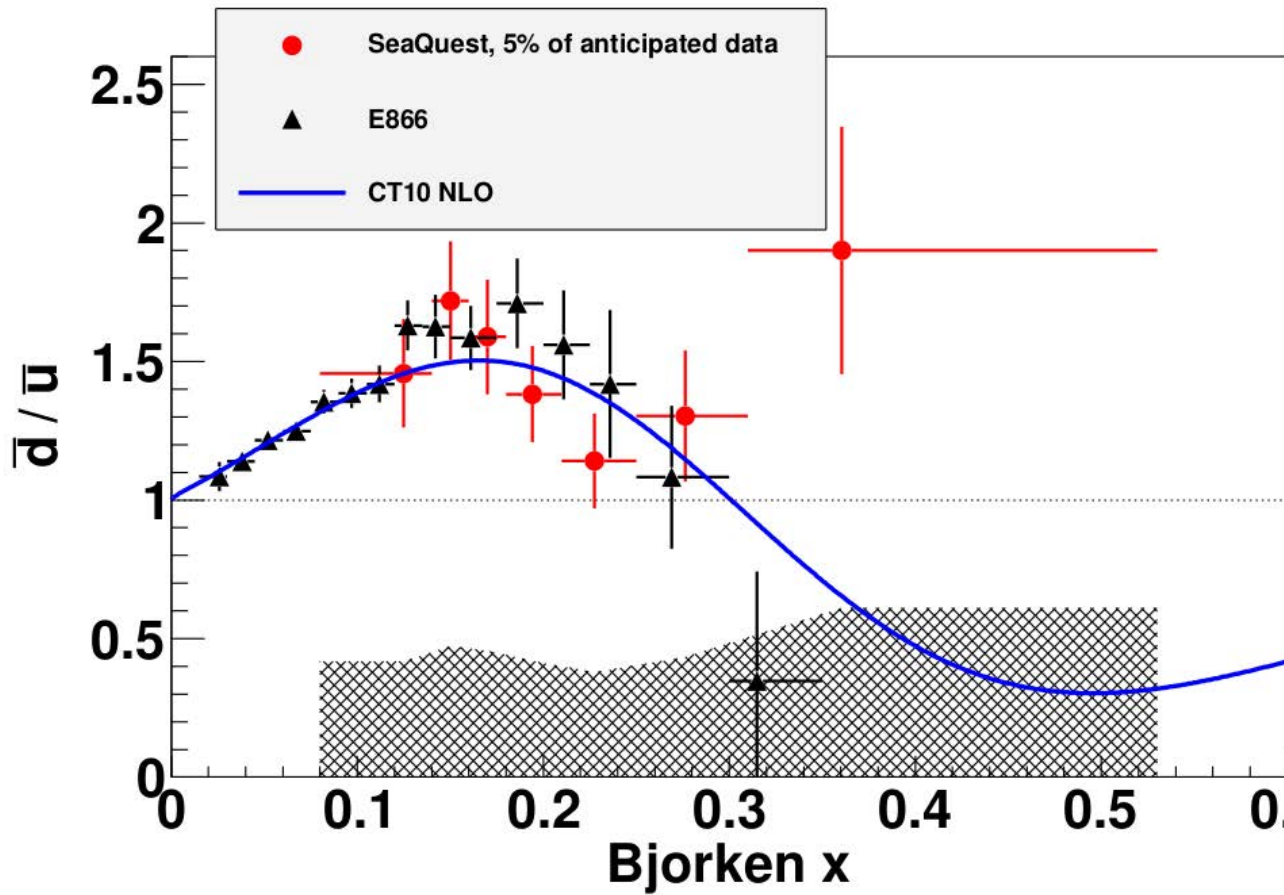

- plot based on fewer than 0.1×10^{18} protons (live)
- 20x more data recorded (1×10^{18}) so far
- anticipate total of 1.4×10^{18} protons by July 2016
- approved for 5×10^{18} pot

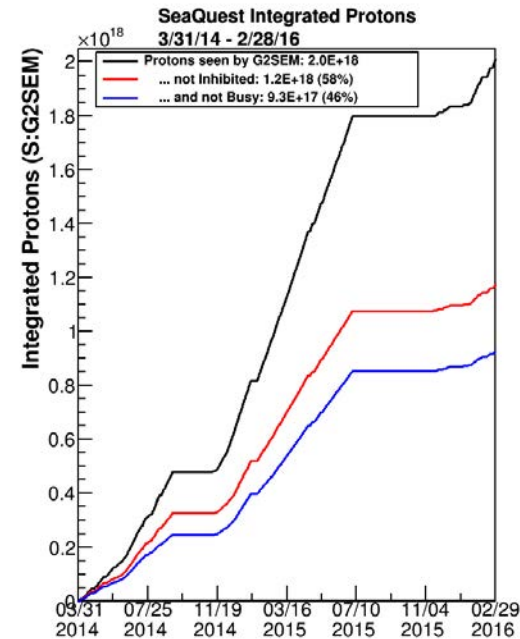

SeaQuest Nuclear Dependence (Preview)

- data Presented by Bryan Dannowitz at April 2015 APS
- no antiquark enhancement apparent
- 10% of anticipated statistical precision
- increased detector acceptance at large- x_T to come (new D1 chamber)

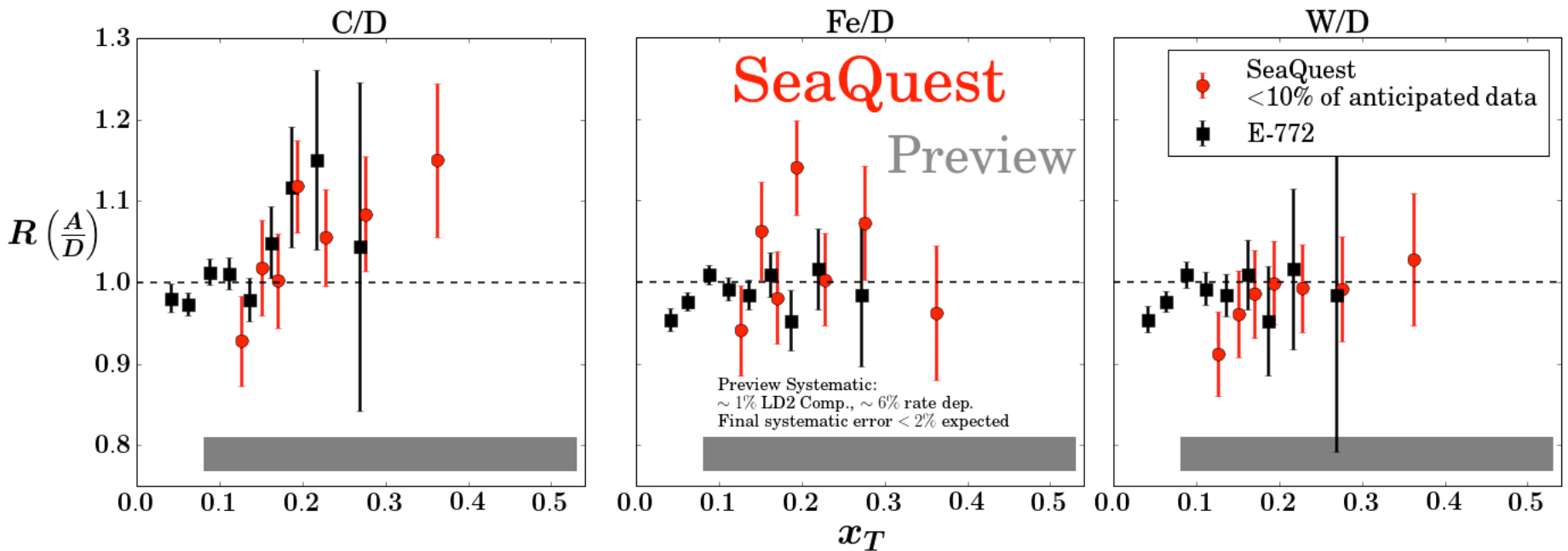

- Preliminary 2015 data set will be presented by Bryan Dannowitz at April 2016 APS – stay tuned

Let's Add a Polarized Target (E-1039)

Target

Polarization: 85%

Packing fraction 0.6

Dilution factor: 0.176

Density: 0.89 g/cm^3

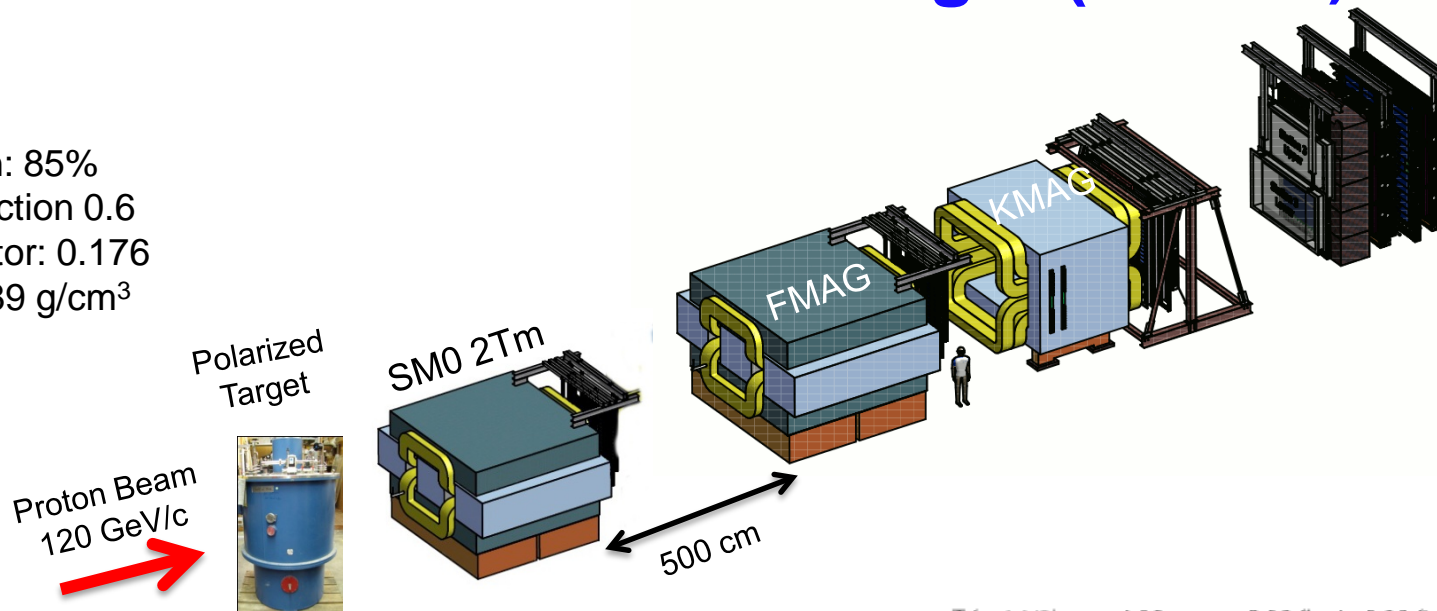

- use current SeaQuest setup, a polarized proton target, unpolarized beam
- add third magnet SM0 ~5m upstream

- improves dump-target separation
- moves $\langle x_t \rangle$ from 0.21 to 0.176
- reduces overall acceptance
- additional shielding

- installation in summer 2017
- supported with Los Alamos LDRD funds

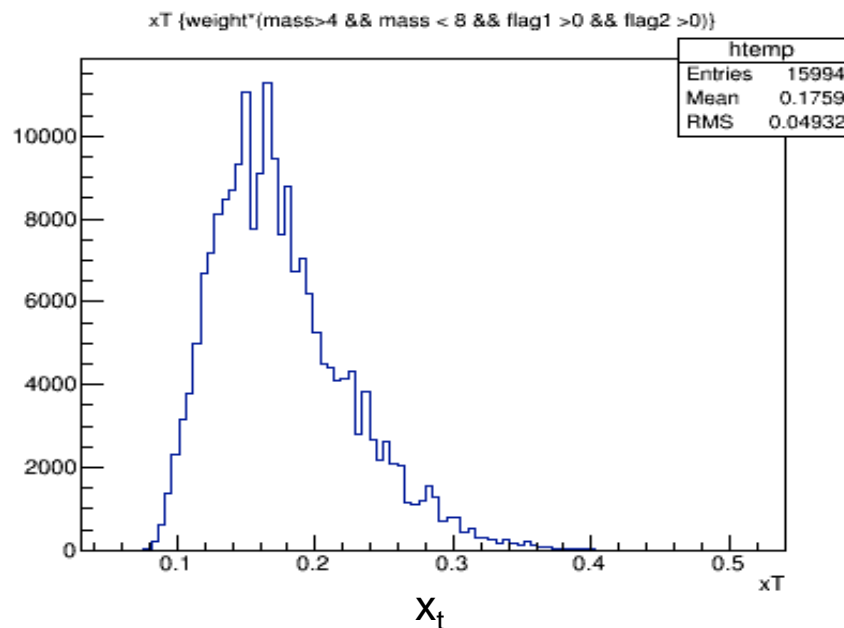

Sivers Function and Spin Crisis

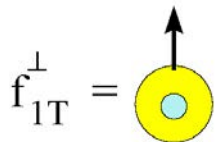

-

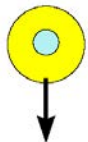

cannot exist w/o quark **OAM**

- describes transverse-momentum distribution of **unpolarized quarks** inside transversely **polarized proton**
- captures **non-perturbative** spin-orbit coupling effects inside a polarized proton

$$\frac{1}{2} = \frac{1}{2} \Delta\Sigma + \Delta G + L \quad \frac{1}{2} \Delta\Sigma \approx 25\%; \quad \Delta G \approx 20\%$$

$$\Delta\Sigma = \Delta u + \Delta d + \Delta s \quad L \approx \text{unmeasured}$$

How measure quark OAM ?

- GPD: Generalized Parton Distribution
- TMD: Transverse Momentum Distribution

$$A_N = \frac{N^\uparrow - N^\downarrow}{N^\uparrow + N^\downarrow} \neq 0$$

$$A_N^{DY} \propto \frac{u(x_b) \cdot f_{1T}^{\perp, \bar{u}}(x_t)}{u(x_b) \cdot \bar{u}(x_t)}$$

Lattice QCD:

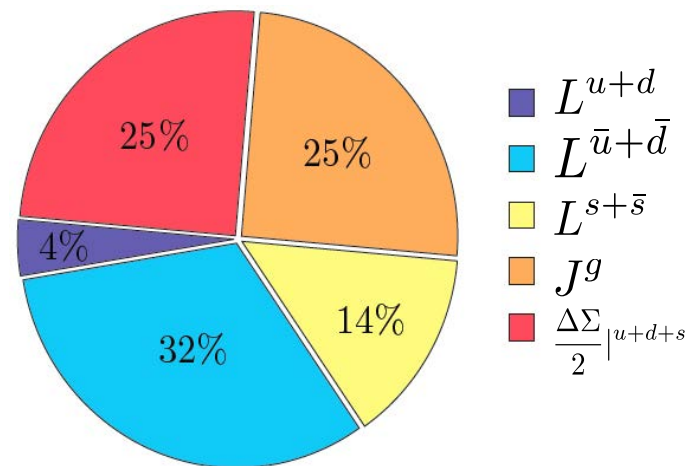

$$\Delta\Sigma_q \approx 25\%$$

$$2 L_q \approx 50\% \quad (4\% \text{ (valence)} + 46\% \text{ (sea)})$$

$$2 J_g \approx 25\%$$

Projected Statistical Precision with a Polarized Target at (E-1039)

- Probe **Sea-quark Sivers Asymmetry** with a polarized proton target at SeaQuest

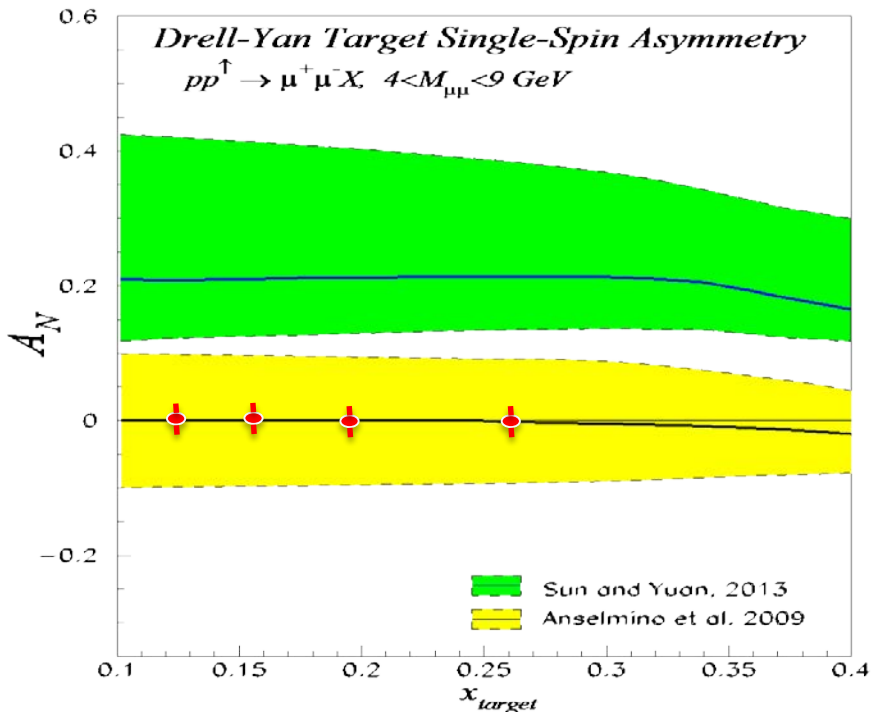

Statistics shown for two calendar years of running:

- $L = 7.2 \cdot 10^{42} / \text{cm}^2 \leftrightarrow \text{POT} = 2.8 \cdot 10^{18}$
- $P = 85\%$

- existing SIDIS data poorly constrain sea-quark Sivers function (Anselmino)
- significant Sivers asymmetry expected from meson-cloud model (Sun & Yuan)
- **first Sea Quark Sivers Measurement**
- **determine sign and value of \bar{u} Sivers distribution**

If $A_N \neq 0$, major discovery:
 “Smoking Gun” evidence for $L_{\bar{u}} \neq 0$

Further Plans with Polarized Targets (E-1039')

- Probe \bar{d} **Sivers Asymmetry** with a polarized ND_3 target at SeaQuest
 - SeaQuest only place to measure \bar{d} (explore during E1039)
 - measure Sivers asymmetry for pp and pD and take ratio
 - requires measuring p and “n” in parallel to control systematics
 - microwave irradiates both targets at the same time
 - one cell NH_3 , the other ND_3
- Probe **Tensor Polarization Deuteron** (40% - 50%)

Target holder

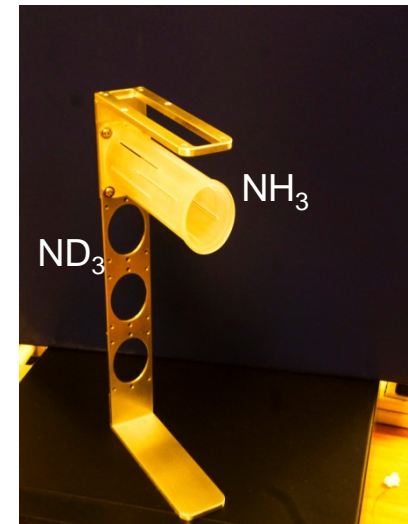

Tensor structure b_1 (e.g. deuteron)

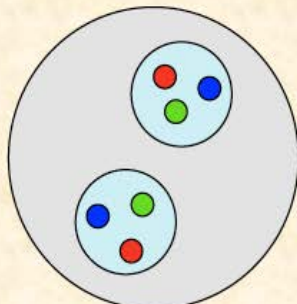

only S wave
 $b_1=0$

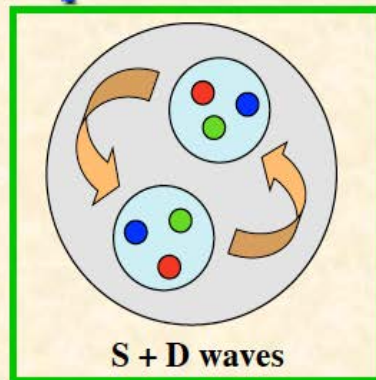

standard model $b_1 \neq 0$

Tensor-structure crisis!?

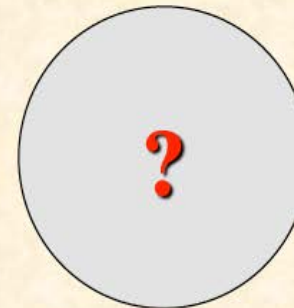

b_1 experiment
 $\neq b_1$ “standard model”

Let's Polarize the Beam at Fermilab (E-1027)

The Plan:

- Use fully understood SeaQuest Spectrometer
- Add polarized beam

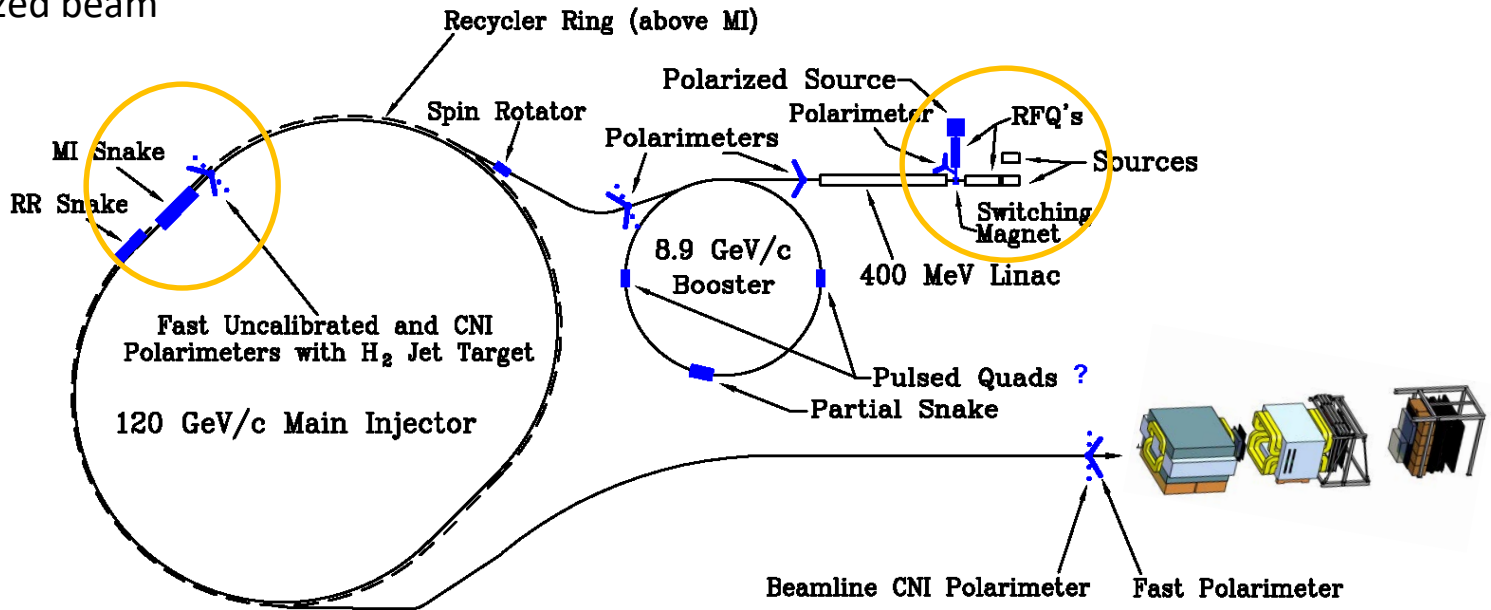

Measure sign-change in Sivers Function:

- QCD (and factorization) require sign change
- major milestone in hadronic physics (HP13)

$$f_{1T}^{\perp} \Big|_{SIDIS} = - f_{1T}^{\perp} \Big|_{DY}$$

Fermilab (best place for polarized DY):

- very high luminosity, large x-coverage, primary beam

Cost Est.: \$6M + \$4M Contingency & Management = \$10M (in 2013)

Expected Precision from E-1027 at Fermilab

- Probe **Valence-quark Sivers Asymmetry** with a polarized proton beam at SeaQuest

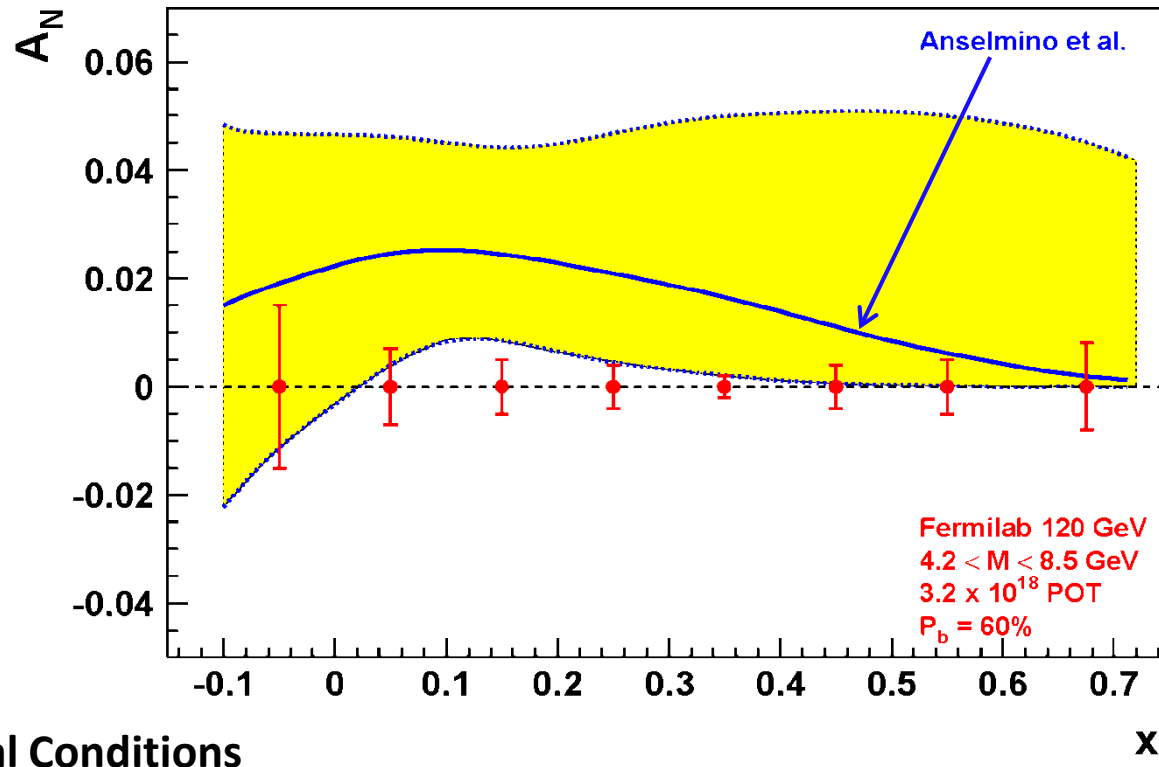

**1.3 Mio
DY events**

Can measure not only sign, but also the size & maybe shape of the Sivers function!

Planned(/running) Polarized Drell-Yan Experiments

Experiment	Particles	Energy (GeV)	x_b or x_t	Luminosity ($\text{cm}^{-2} \text{s}^{-1}$)	$A_T^{\sin \phi_S}$	P_b or P_t (f)	rFOM#	Timeline
COMPASS (CERN)	$\pi^\pm + p^\uparrow$	160 GeV $\sqrt{s} = 17$	$x_t = 0.1 - 0.3$	2×10^{33}	0.14	$P_t = 90\%$ $f = 0.22$	1.1×10^{-3}	2015-2016, 2018
PANDA (GSI)	$\bar{p} + p^\uparrow$	15 GeV $\sqrt{s} = 5.5$	$x_t = 0.2 - 0.4$	2×10^{32}	0.07	$P_t = 90\%$ $f = 0.22$	1.1×10^{-4}	>2018
PAX (GSI)	$p^\uparrow + \bar{p}$	collider $\sqrt{s} = 14$	$x_b = 0.1 - 0.9$	2×10^{30}	0.06	$P_b = 90\%$	2.3×10^{-5}	>2020?
NICA (JINR)	$p^\uparrow + p$	collider $\sqrt{s} = 26$	$x_b = 0.1 - 0.8$	1×10^{31}	0.04	$P_b = 70\%$	6.8×10^{-5}	>2018
PHENIX/STAR (RHIC)	$p^\uparrow + p^\uparrow$	collider $\sqrt{s} = 510$	$x_b = 0.05 - 0.1$	2×10^{32}	0.08	$P_b = 60\%$	1.0×10^{-3}	>2018
fsPHENIX (RHIC)	$p^\uparrow + p^\uparrow$	$\sqrt{s} = 200$ $\sqrt{s} = 510$	$x_b = 0.1 - 0.5$ $x_b = 0.05 - 0.6$	8×10^{31} 6×10^{32}	0.08	$P_b = 60\%$ $P_b = 50\%$	4.0×10^{-4} 2.1×10^{-3}	>2021
SeaQuest (FNAL: E-906)	$p + p$	120 GeV $\sqrt{s} = 15$	$x_b = 0.35 - 0.9$ $x_t = 0.1 - 0.45$	3.4×10^{35}	---	---	---	2012 - 2017
Pol tgt DY[‡] (FNAL: E-1039)	$p + p^\uparrow$	120 GeV $\sqrt{s} = 15$	$x_t = 0.1 - 0.45$	4.4×10^{35}	0 - 0.2*	$P_t = 85\%$ $f = 0.176$	0.15	2018-2019
Pol beam DY[§] (FNAL: E-1027)	$p^\uparrow + p$	120 GeV $\sqrt{s} = 15$	$x_b = 0.35 - 0.9$	2×10^{35}	0.04	$P_b = 60\%$	1	2020

[‡] 8 cm NH₃ target / [§] $L = 1 \times 10^{36} \text{ cm}^{-2} \text{ s}^{-1}$ (LH₂ tgt limited) / $L = 2 \times 10^{35} \text{ cm}^{-2} \text{ s}^{-1}$ (10% of MI beam limited)

*not constrained by SIDIS data / # rFOM = relative lumi * P² * f² wrt E-1027 (f=1 for pol p beams, f=0.22 for π^- beam on NH₃)

A Novel, Compact Siberian Snake for the Main Injector

Single snake design (6.4m long):

- 1 helical dipole + 2 conv. dipoles
 - helix: 4T / 5.6 m / 4" ID
 - dipoles: 4T / 0.2 m / 4" ID
- use 4-twist magnets
 - 8π rotation of B field
- never done before in a high energy ring
 - RHIC uses snake pairs
 - 4 single-twist magnets (2π rotation)

initial design studies

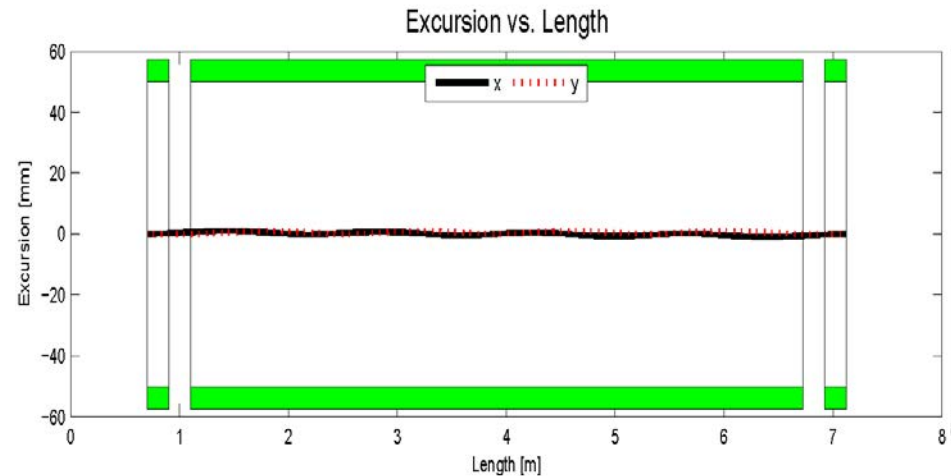
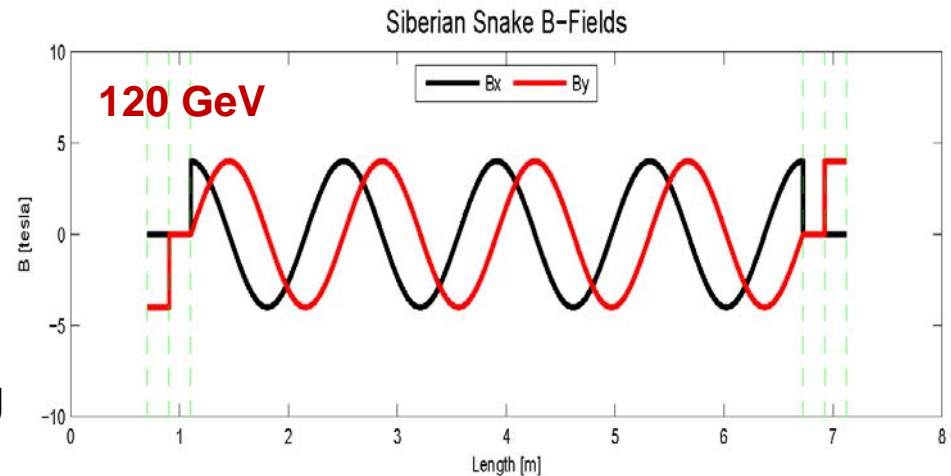

beam excursions shrink w/
beam energy

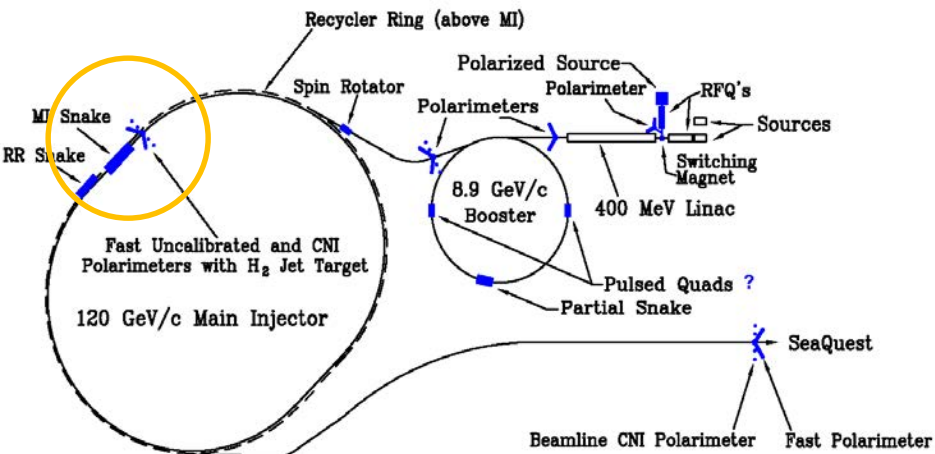

Differences compared to RHIC

- **Most significant difference:**
 Ramp time of **Main Injector < 0.7 s**, at **RHIC 1-2 min**
 - **warm magnets** at MI vs. superconducting at RHIC
 - pass through all depolarizing resonances much more quickly
- Beam remains in **MI ~2 s**, in **RHIC ~8 hours**
 - **extracted beam** vs. **storage ring**
 - much **less** time for **cumulative depolarization**
- **Disadvantage** compared to RHIC — no **institutional history** of accelerating polarized proton beams
 - Fermilab E704 had polarized beams through hyperon decays

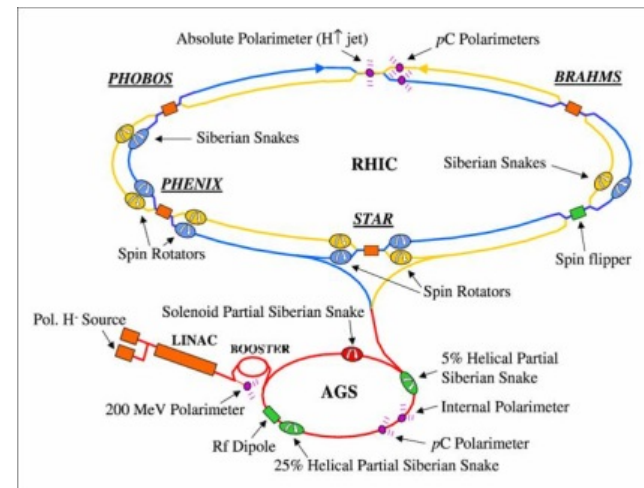
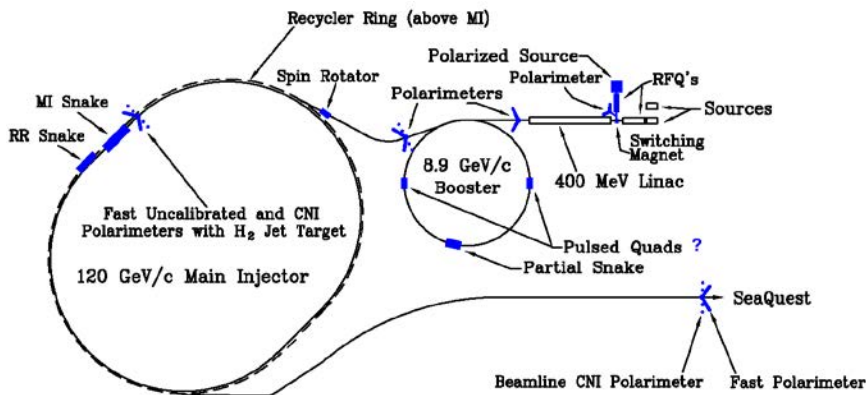

The Path to a polarized Main Injector

Stage 1 approval from Fermilab: 14-November-2012

- **PAC request:** detailed machine design and costing using 1 snake in MI
- Collaboration with A.S. Belov at INR and Dubna to develop polarized source
- During 2013 - 2014:
 - set up Zgoubi spin-tracking package (M. Bai, F. Meot, BNL)
 - single particle tracking, emittance, momentum spread of particles
 - conceptual design that works *at least for a perfect machine* — perfect magnet alignment, perfect orbits, no momentum spread, etc
 - but slow and limited support:
difficulties implementing orbit errors, quadrupole mis-alignments/rolls, ramp rates
- **Fermilab AD support:** 2015-2016
 - Meiqin Xiao from AD set up PTC (Etienne Forest, KEK)
 - repeated Zgoubi work in 1 month
 - “easy” to include orbit errors, quadrupole mis-alignments/rolls, ramp rates
 - support for one year
 - plan to complete simulations
 - go back to PAC

Simulation of final polarization as function of Energy

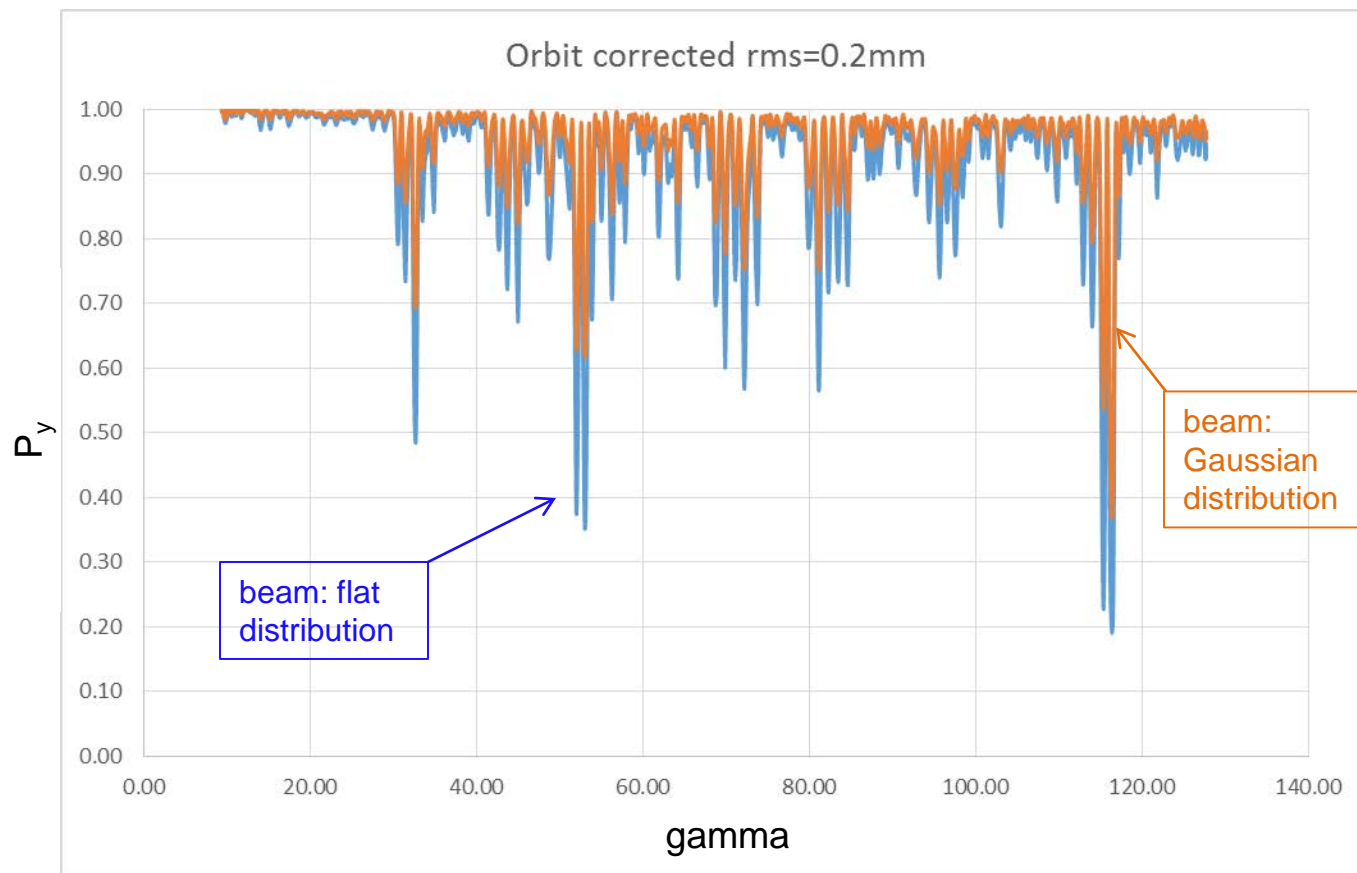

Point-like snake in correct location, actual ramp rate for acceleration.

Polarizations with magnet field error and misalignment (from magnet database and survey group), **corrected** (for SeaQuest running conditions)

Final polarization: > 90%

$\epsilon_{\max} = 20 \pi$ mm.mrad in y plane and $\Delta p = 1.25 \cdot 10^{-3}$ in longitudinal plane

Simulation of final polarization as function of Energy

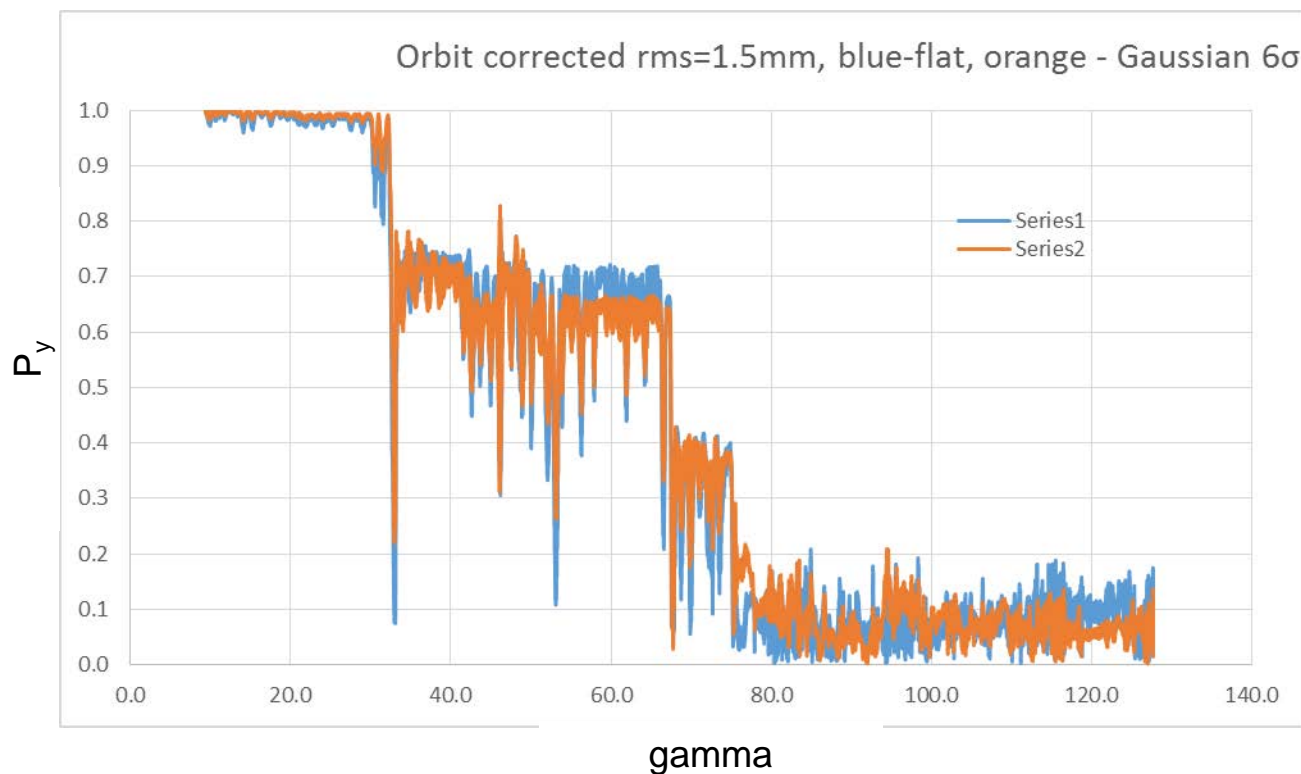

Point-like snake in correct location, actual ramp rate for acceleration.

Polarizations with magnet field error and misalignment, partially corrected

Final polarization: < 10%

$\epsilon_{\max} = 20 \pi$ mm.mrad in y plane and $\Delta p = 1.25 \cdot 10^{-3}$ in longitudinal plane

Exploring the Dark Side of the Universe

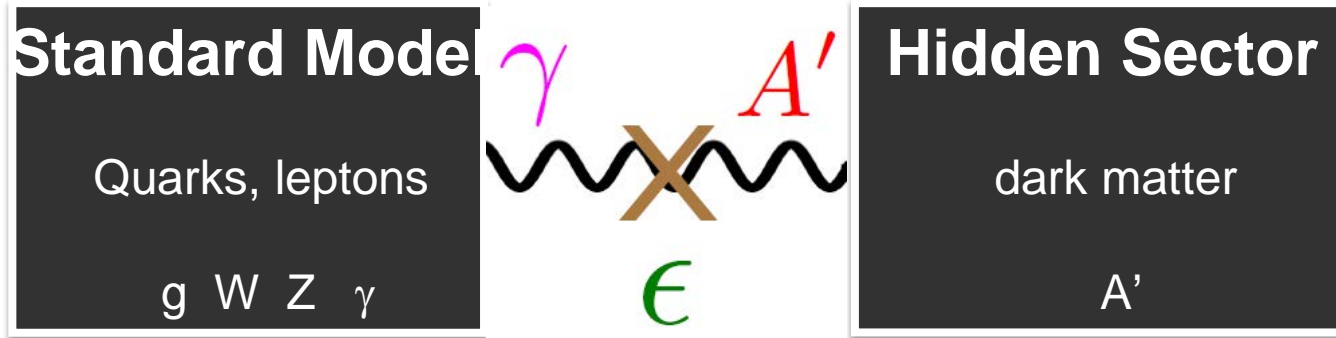

- Dark sector could interact with the standard model sector via a hidden gauge boson (A' or “dark photon” or “para photon” or “hidden photon”)
- Dark photons can provide a portal into the dark sector
- Dark photons could couple to standard model matter with $\alpha' = \alpha\epsilon^2$

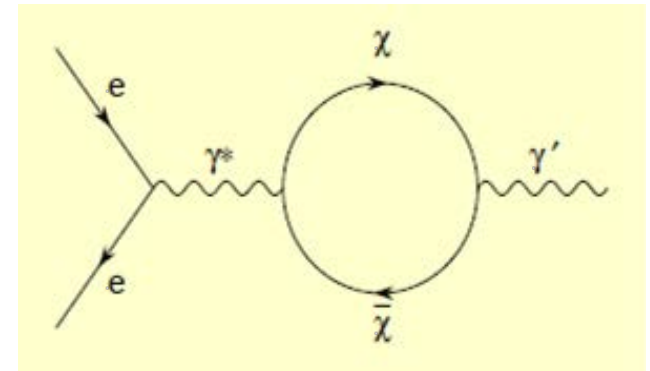

A' produced via a loop mechanism

B. Holdom, PLB **166** (1986) 196
 J. D. Bjorken et al, PRD **80** (2009) 075018

$\epsilon \sim 10^{-2}$ to 10^{-8} from loops of heavy particles

Possible Mechanisms for producing A' at SeaQuest

- Proton Bremsstrahlung

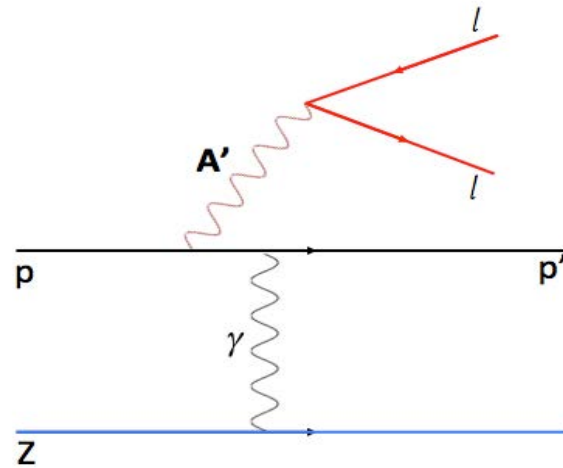

- η ... decay

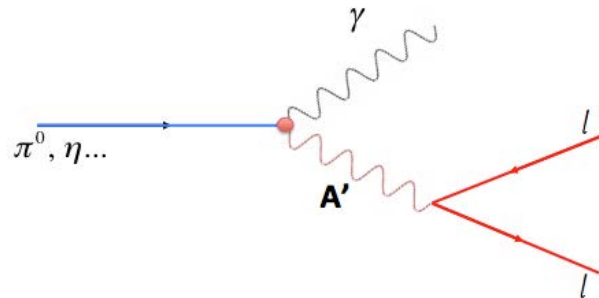

- Drell-Yan process

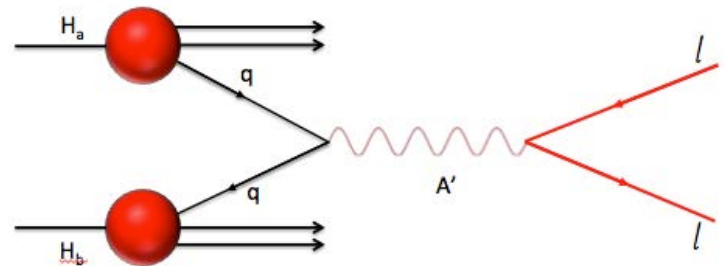

SeaQuest A' search strategy

- Classic Beam Dump Experiment

- A' generated by η decay and/or proton Bremsstrahlung in the Iron beam dump
- A' could travel a distance l_0 without interacting
- A' decays into di-leptons
- Reconstructed di-lepton vertex is **displaced**, downstream of the target in the beam dump

- Minimal impact on Drell-Yan program

- run parasitically during E906

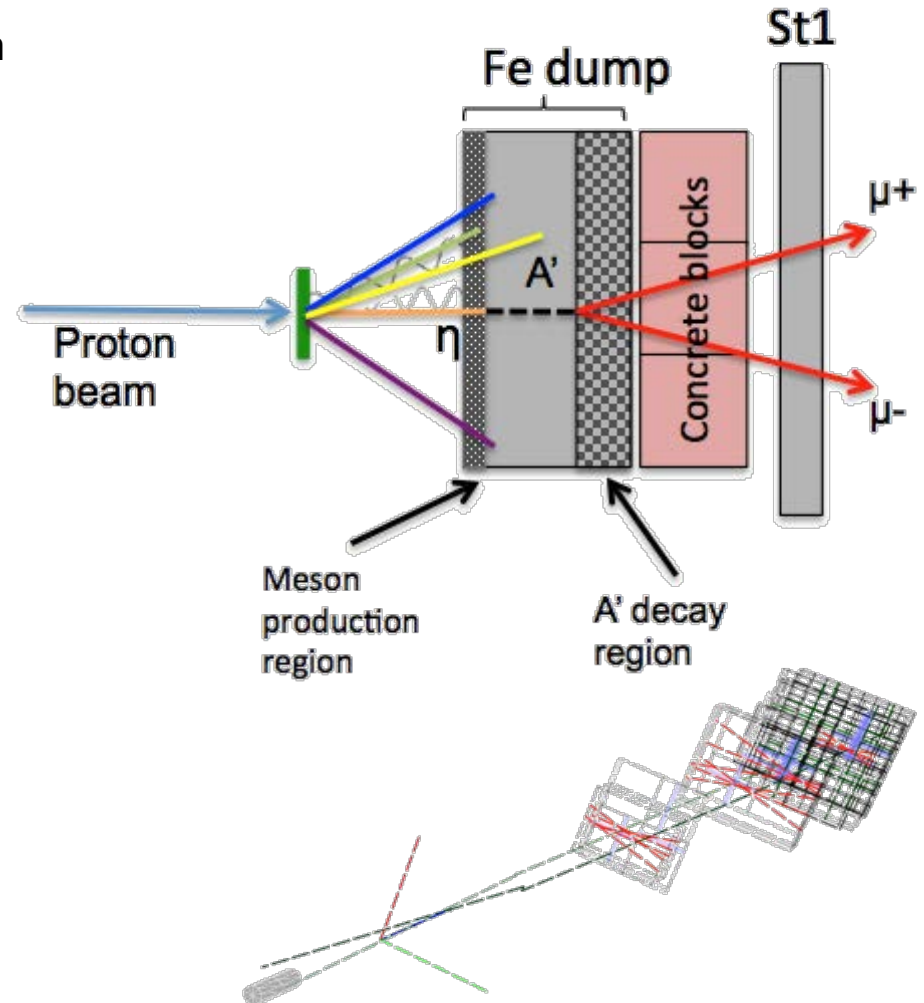

A' sensitivity region for SeaQuest

$$l_o \approx \frac{0.8 \text{ cm}}{N_{\text{eff}}} \left(\frac{E_o}{10 \text{ GeV}} \right) \left(\frac{10^{-4}}{\varepsilon} \right)^2 \left(\frac{100 \text{ MeV}}{m_{A'}} \right)^2$$

J. D. Bjorken et al, PRD **80** (2009) 075018

- E_o = energy of the A'
 - $E_o = 5 - 20 \text{ GeV}$ for η decay
 - $E_o = 5 - 110 \text{ GeV}$ for Proton Bremsstrahlung
- N_{eff} = no. of available decay products
 - $N_{\text{eff}} = 2$
- l_o = distance that A' travels before decaying
 - $l_o = 0.17\text{m} - 5.95\text{m}$
- ε = coupling constant between standard model and dark sector
- $m_{A'}$ = mass of A'

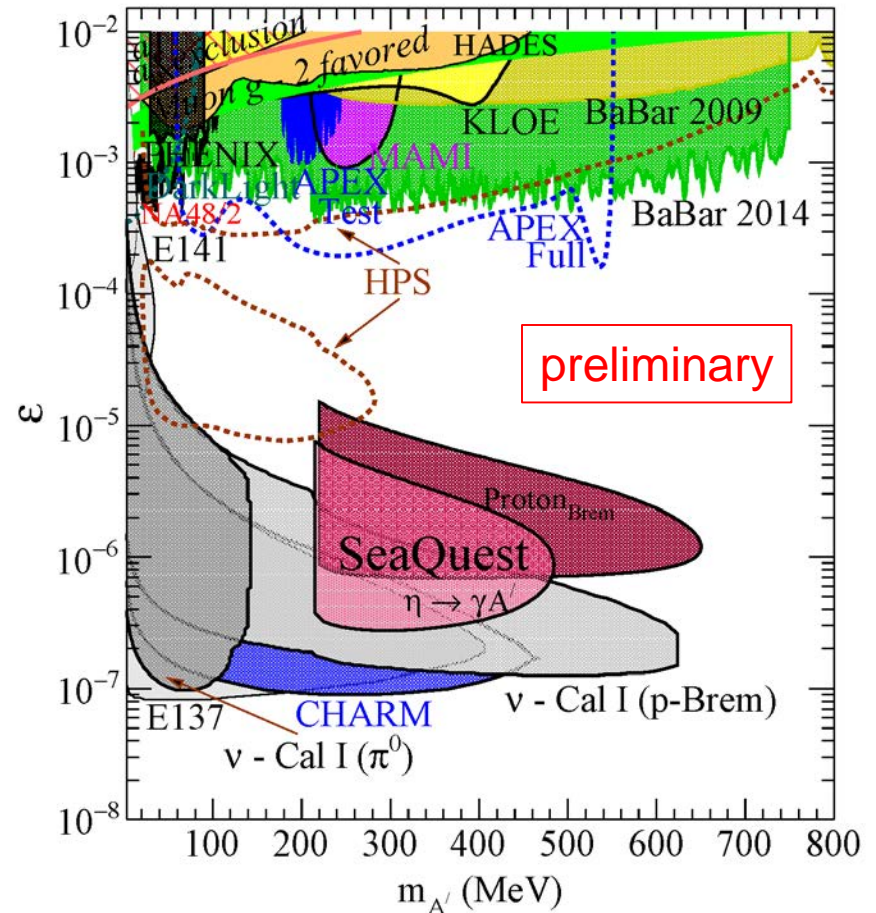

η decay: limited to A' mass less than the meson mass

Polarized Proton Beams and Searches for Dark Forces

Searches for a dark photon also limit other possibilities

Parity violation studies could prove key

$$\mathcal{L}_{\text{darkZ}} = -(\varepsilon e J_{\text{em}}^\mu + \varepsilon_Z \frac{g}{2 \cos \theta_W} J_{\text{NC}}^\mu) Z_{d\mu}$$

[Davoudiasl, Lee, Marciano, 2014]

If the A' is a dark Z , then ...

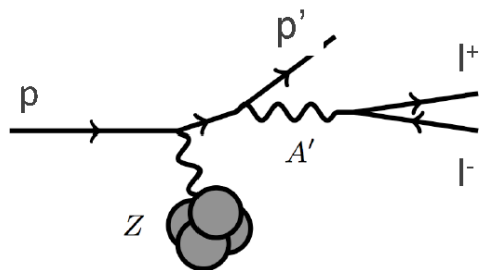

The dilepton yield can change
with proton polarization:
the asymmetry
can be $O(1)$!

E-1027, E-1039 (and Beyond)

	Beam Pol.	Target Pol.	Favored Quarks	Physics Goals				
				(Sivers Function)			L_{sea}	A', Z_d
				sign change	size	shape		
E-1027 $p^\uparrow p \rightarrow \mu^+ \mu^- X$	✓	✗	valence	✓	✓	✓	✗	✓
E-1039 $p p^\uparrow \rightarrow \mu^+ \mu^- X$	✗	✓	sea	✗	✓	(✓)	✓	✓
E-10XX $p^\uparrow p^\uparrow \rightarrow \mu^+ \mu^- X$ $\vec{p} \vec{p} \rightarrow \mu^+ \mu^- X$	✓	✓	sea & valence	Transversity, Helicity, Other TMDs ...				

Double-Spin Drell-Yan

→ rich, high-lumi spin-physics: complementary to RHIC and JLab

Drell-Yan Physics Program at Fermilab

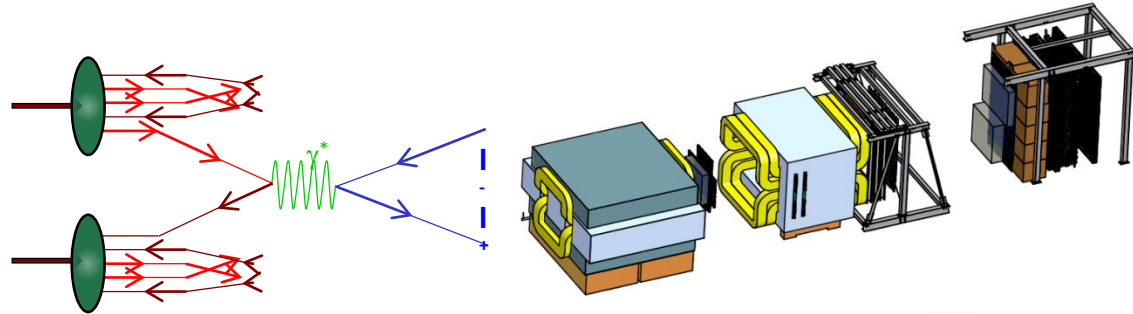

Sea Quarks of the Target

- $d\bar{u}$ / $u\bar{d}$
- Sea quark EMC effect

Not discussed:

- Quark sea absolute magnitude
- Partonic Energy Loss
- J/ψ Nuclear Dependence

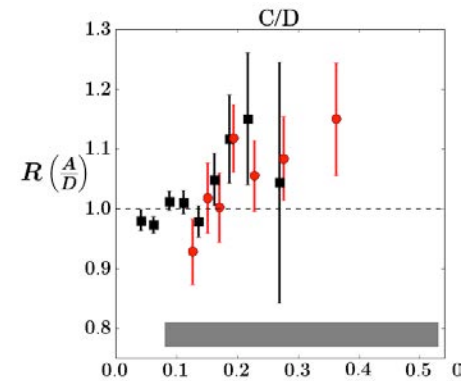
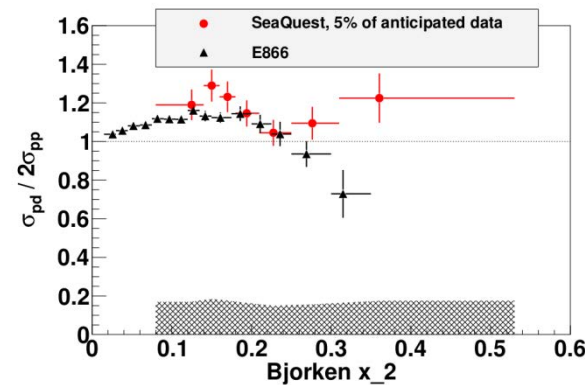

Transverse Spin Physics

- Sivers and OAM of Sea Quarks
- Sivers and QCD on Valence Quarks (sign change))

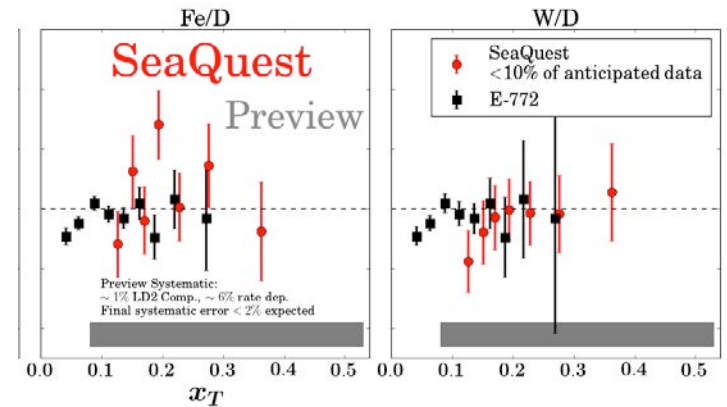
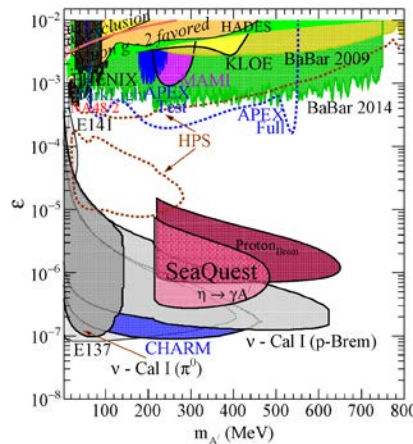

Dark Photons?

Thank You

Backup Slides

A' sensitivity region for SeaQuest

$$l_o \approx \frac{0.8 \text{ cm}}{N_{\text{eff}}} \left(\frac{E_o}{10 \text{ GeV}} \right) \left(\frac{10^{-4}}{\varepsilon} \right)^2 \left(\frac{100 \text{ MeV}}{m_{A'}} \right)^2$$

J. D. Bjorken et al, PRD **80** (2009) 075018

- E_o = energy of the A'
 - $E_o = 5 - 20 \text{ GeV}$ for η decay
 - $E_o = 5 - 110 \text{ GeV}$ for Proton Bremsstrahlung
- N_{eff} = no. of available decay products
 - $N_{\text{eff}} = 2$
- l_o = distance that A' travels before decaying
 - $l_o = 0.17\text{m} - 5.95\text{m}$
- ε = coupling constant between standard model and dark sector
- $m_{A'}$ = mass of A'

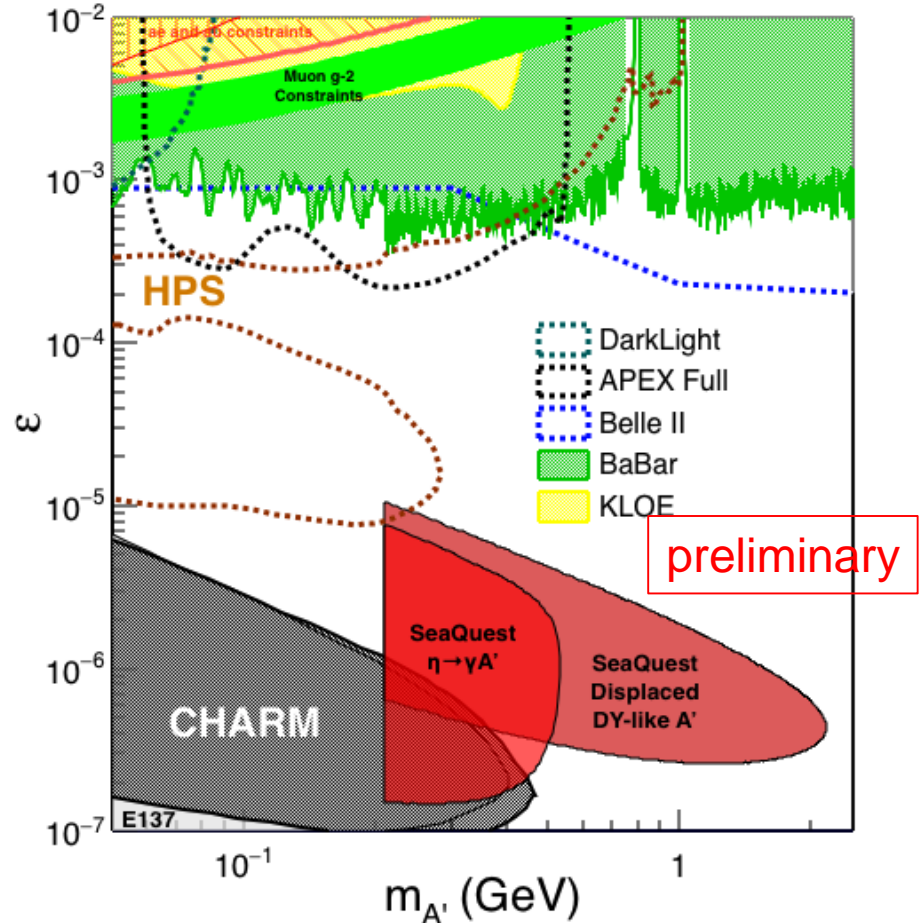

DY-like: can access A' with larger mass

Dark Photons: SeaQuest vs. SHiPS

“apples & oranges”

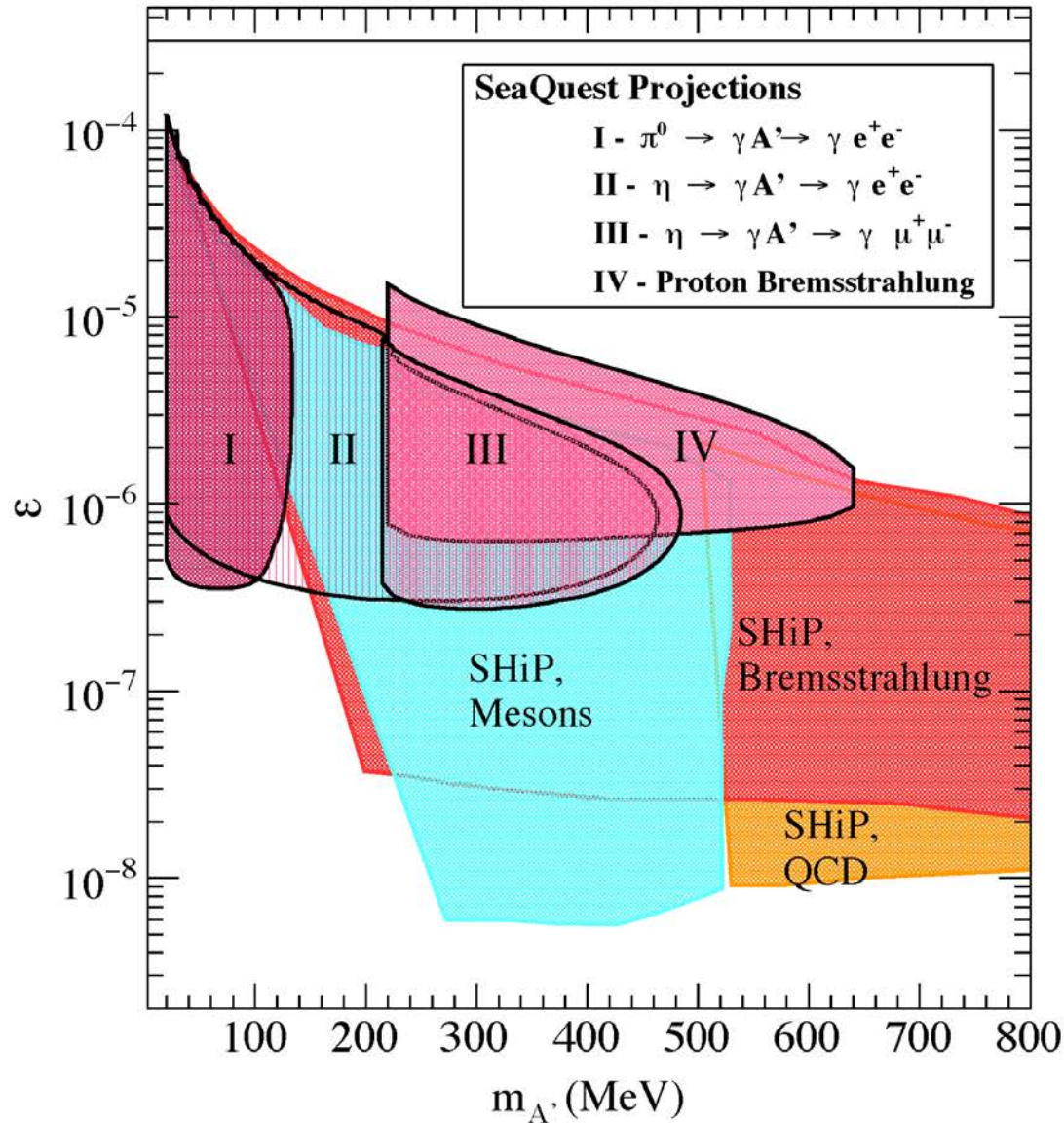

5 yr exposure
400 GeV beam
opt. detectors
vs.
1 yr exposure
120 GeV beam
SeaQuest spect.

**Sharper constraints
are possible!**

SeaQuest Projections for absolute cross sections

- Measure high x structure of beam proton
 - large x_F gives large x_{beam}
- High x distributions poorly understood
 - nuclear corrections are large, even for deuterium
 - lack of proton data
- In pp cross section, no nuclear corrections
- Measure convolution of beam and target PDF
 - absolute magnitude of high x valence distributions ($4u+d$)
 - absolute magnitude of the sea in target ($\bar{d} + \bar{u}$)
(currently determined by ν -Fe DIS)

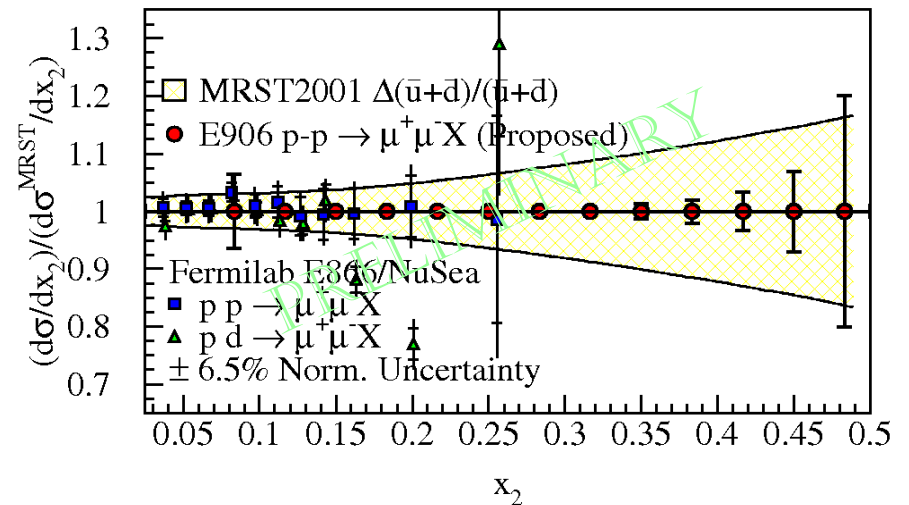
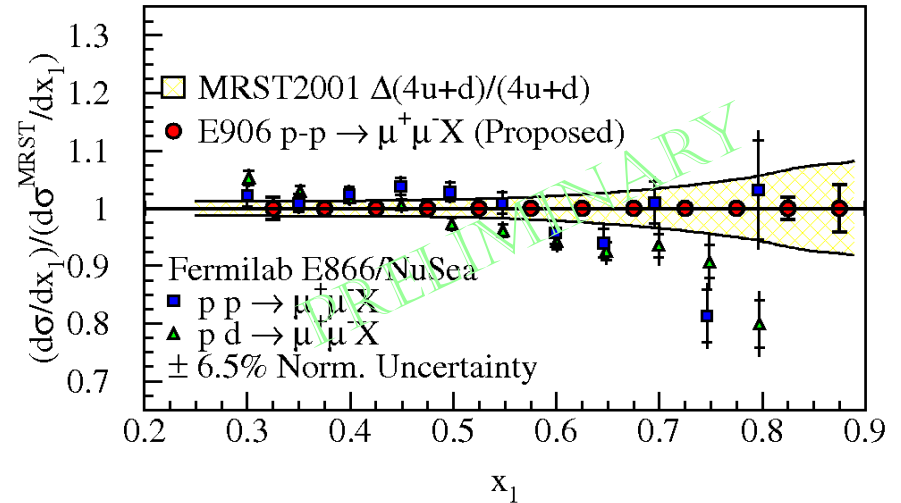

Partonic Energy Loss in Cold Nuclear Matter

- An understanding of partonic energy loss in both cold and hot nuclear matter is paramount to elucidating RHIC data.
- Pre-interaction parton moves through cold nuclear matter and loses energy.
- Apparent (reconstructed) kinematic value (x_1 or x_F) is shifted
- Fit shift in x_1 relative to deuterium

Parton Loses Energy in Nuclear Medium

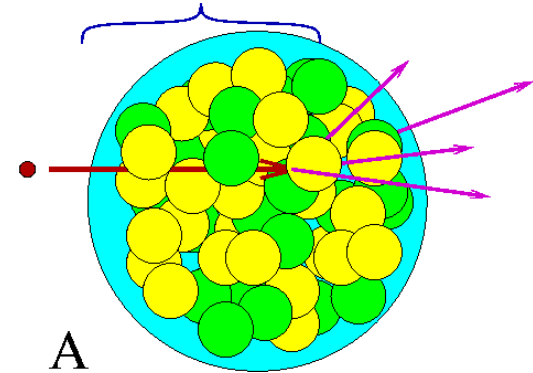

→ shift in $\Delta x_1 \propto 1/s$ (larger at 120 GeV)

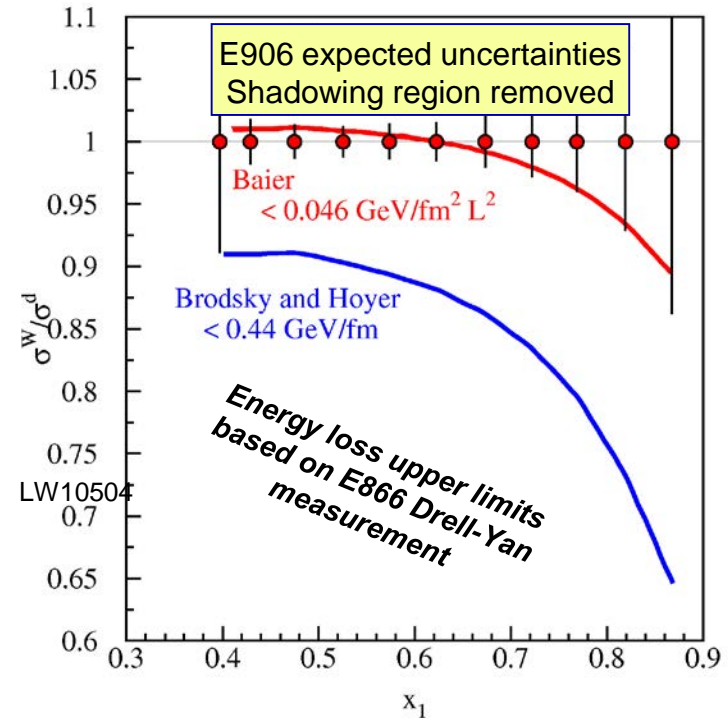
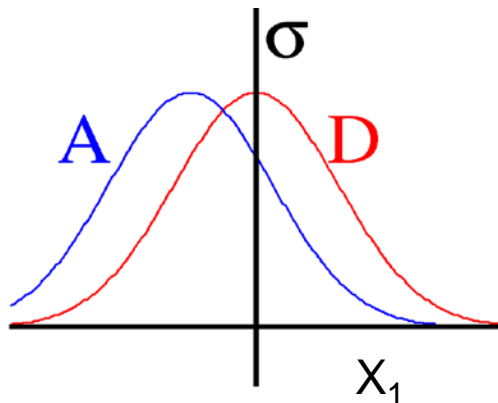

- E906 will have sufficient statistical precision to allow events within the shadowing region, $x_2 < 0.1$, to be removed from the data sample

Fermilab E906/SeaQuest Collaboration

Abilene Christian University

Ryan Castillo, Michael Daugherty, Donald Isenhower, Noah Kitts, Lacey Medlock, Noah Shutty, Rusty Towell, Shon Watson, Ziao Jai Xi

Academia Sinica

Wen-Chen Chang, Shiu Shiuan-Hao

Argonne National Laboratory

John Arrington, Don Geesaman*, Kawtar Hafidi, Roy Holt, Harold Jackson, Michelle Mesquita de Medeiros, Bardia Nadim, Paul E. Reimer*

University of Colorado

Ed Kinney, Po-Ju Lin

Fermi National Accelerator Laboratory

Chuck Brown, Dave Christian, Gabriele Garzoglio, Su-Yin (Grass) Wang, Jin-Yuan Wu

University of Illinois

Bryan Dannowitz, Markus Diefenthaler, Bryan Kerns, Hao Li, Naomi C.R Makins, Dhyaanesh Mullagur R. Evan McClellan, Jen-Chieh Peng, Shivangi Prasad, Mae Hwee Teo, Mariusz Witek, Yangqiu Yin

KEK

Shin'ya Sawada

Los Alamos National Laboratory

Gerry Garvey, Xiaodong Jiang, Andreas Klein, David Kleinjan, Mike Leitch, Kun Liu, Ming Liu, Pat McGaughey

Mississippi State University

Lamiaa El Fassi

University of Maryland

Betsy Beise, Andrew (Yen-Chu) Chen

University of Michigan

Christine Aidala, McKenzie Barber, Catherine Culkin, Vera Loggins, Wolfgang Lorenzon, Bryan Ramson, Richard Raymond, Josh Rubin, Matt Wood

National Kaohsiung Normal University

Rurngsheng Guo

RIKEN

Yuji Goto

Rutgers, The State University of New Jersey

Ron Gilman, Ron Ransome, Arun Tadepalli

Tokyo Tech

Shou Miyaska, Kei Nagai, Kenichi Nakano, Shigeki Obata, Toshi-Aki Shibata

Yamagata University

Yuya Kudo, Yoshiyuki Miyachi, Shumpei Nara

*Co-Spokespersons



Fermilab Polarized Drell-Yan Collaborating Institutes

Polarized Target:

Argonne National Laboratory
Fermi National Accelerator Laboratory
Institute of Physics, Academia Sinica
KEK
Ling-Tung University
Los Alamos National Laboratory
University of Maryland
University of Michigan
University of New Hampshire
National Kaohsiung Normal University
RIKEN
Rutgers University
Thomas Jefferson National Accelerator Facility
Tokyo Tech
University of Virginia

**Andi Klein and Xiaodong Jiang
Co-Spokespersons**

Polarized Beam:

Abilene Christian University
Argonne National Laboratory
University of Basque Country
University of Colorado
Fermi National Accelerator Laboratory
University of Illinois
KEK
Los Alamos National Laboratory
University of Maryland
University of Michigan
RIKEN
Rutgers
Tokyo Tech
Yamagata University

**Wolfgang Lorenzon and Paul E Reimer
Co-Spokespersons**

